

*Professional*TM
380

Pocket Service Guide

1st Edition, September 1984
2nd Edition, December 1984
3rd Edition, June 1986

Copyright © 1984, 1986 by Digital Equipment Corporation.
All Rights Reserved.

Printed in U.S.A.

The reproduction of this material, in part or whole, is strictly prohibited. For copy information, contact the Educational Services Department, Digital Equipment Corporation, Maynard, Massachusetts 01754.

The information in this document is subject to change without notice. Digital Equipment Corporation assumes no responsibility for any errors that may appear in this document.

CP/M is a trademark of Digital Research, Inc.

Velcro is a trademark of Velcro, USA, Inc.

Velostat is a trademark of 3M Company.

The following are trademarks of Digital Equipment Corporation, Maynard, Massachusetts.

digital	DECwriter	RSTS
CTI Bus	DELNI	RSX
DEC	DIBOL	UNIBUS
DECmate	MASSBUS	VAX
DECnet	PDP	VMS
DECsystem-10	P/OS	VT
DECSYSTEM-20	Professional	Work Processor
DECUS	Rainbow	

CONTENTS

INTRODUCTION

CHAPTER 1 TROUBLESHOOTING AND TESTING

1.1	General	1
1.1.1	Troubleshooting Notes	1
1.1.2	Physical Differences Between the Professional 380 and 325/350	1
1.2	Troubleshooting with Tests	2
1.3	Power-Up Self-Test	2
1.4	Maintenance Services Tests	2
1.4.1	Running the Maintenance Application Diskette	4
1.4.2	Customer Mode and Service Mode	4
1.4.3	System Unit Test	5
1.4.4	Keyboard Test	7
1.4.5	Printer Test	8
1.4.6	Configuration Display Program	9
1.4.7	Bar Pattern Program	11
1.4.8	Video Alignment Pattern Program	11
1.4.9	Update Maintenance Services	12
1.4.10	Bigdisk Block Check	12
1.4.11	Minidisk Block Check	13
1.4.12	RX Speed Test	14
1.4.13	Fast Formatter	15
1.5	No Response at Power-Up	15
1.6	System and Boot Problems	20
1.7	System Failure with Boot	20
1.8	Boot Problems	34
1.8.1	Boot Failures	34
1.9	System Software Error	34
1.10	Keyboard Problems	34
1.11	Printer Problems	38
1.12	Communications Problems	38
1.13	Diskette Problems	38
1.14	Hard Disk Problems	38

1.15	Tests for Options	40
1.15.1	CP/M Option	40
1.15.2	Real-Time Interface	40
1.15.3	Telephone Management System	41
1.15.4	DECNA Controller	43
1.16	The Analog Data Module (ADM)	43
1.16.1	ADM Troubleshooting – System Unit Test	44
1.16.2	FRU Isolation	45
1.16.3	Troubleshooting	46
1.17	Serial Line Unit Option	51
1.17.1	SLU Configuration	51
1.17.2	Power-Up Self-Test	53
1.17.3	SLU Service Diagnostic	53
1.18	Hard Disk Expander Box Option	54
1.18.1	Power-Up Self-Test	55
1.18.2	Service Diagnostic	55

CHAPTER 2 REMOVAL AND REPLACEMENT

2.1	General	58
2.2	Removal and Replacement Procedures	58
2.3	Top Cover	60
2.4	RX50 Diskette Drive	63
2.5	RD Hard Disk Controller	65
2.6	RD Hard Disk Drive	66
2.7	RD50/51 Hard Disk Drive Read/Write Board	68
2.7.1	DIP Shunt Replacement (RD50/51 Hard Disk Drive)	71
2.7.2	RD52 Board	73
2.7.3	RD31 Device Electronics Board	75
2.8	Power Supply	79
2.9	System Module	80
2.10	Extended Bit Map and Memory Daughter Boards	88
2.11	Battery Pack	88
2.12	I/O Boards	91
2.12.1	Real-Time Interface	94
2.12.2	Telephone Management System (TMS)	97
2.13	Keyboard	98
2.14	Removing and Replacing the Analog Data Module (ADM)	99
2.14.1	Opening the ADM Chassis	99
2.14.2	Removing and Replacing the Power Supply	101

2.14.3	Removing and Replacing the LED Board	102
2.14.4	Removing and Replacing the Motherboard	105
2.14.5	Removing and Replacing the Digital I/O Board	106
2.15	Hard Disk Expander Box	106
2.15.1	Hard Disk Drive	106
2.15.2	Power Supply	115
2.15.3	Load Resistor Assembly	117
2.16	Serial Line Unit Option	118
2.17	Recommended Spares Lists	122

CHAPTER 3 VIDEO MONITOR ALIGNMENT

3.1	General	126
3.2	Monitor Adjustments	126
3.2.1	Removing the Monochrome Monitor ...	126
3.2.2	Monochrome Monitor Cover	129
3.2.3	Preparations for Alignment	130
3.2.4	Vertical Hold	132
3.2.5	Horizontal Hold	132
3.2.6	Focus	132
3.2.7	Vertical Centering and Rotation	133
3.2.8	Horizontal Centering	134
3.2.9	Aspect Ratio (Horizontal Width and Height)	135
3.2.10	Vertical Linearity	136

CHAPTER 4 TESTING AND TROUBLESHOOTING THE DELNI UNIT

4.1	General	137
4.2	Testing the DELNI Unit	137
4.3	Testing the Transceiver Cable	138
4.4	Software Problems	139

APPENDIX A RELATED DOCUMENTATION

APPENDIX B FRU EXPLODED VIEW DRAWINGS

APPENDIX C PHYSICAL/FUNCTIONAL DIAGRAMS

FIGURES

1-1	Power-Up Troubleshooting Diagram	3
1-2	Self-Test Diagram	20
1-3	DECNA Loopback Connector Test Points	44
1-4	Analog Data Module (ADM)	44
1-5	ADM FRUs	45
1-6	SLU Option Kit	52
1-7	SLU Configuration and Cabling	52
2-1	FRU Removal Sequence	59
2-2	Power Switch and AC Power Cord	60
2-3	Circuit Breaker	61
2-4	Diskette Drive Door(s)	61
2-5	Top Cover Releases	62
2-6	Removing Top Cover	62
2-7	I/O Cable and DC Power Cable	63
2-8	Diskette Drive Release Tab	64
2-9	Removing Diskette Drive	65
2-10	Disconnecting I/O Cables from I/O Board	66
2-11	Hard Disk Drive Release Tab	67
2-12	4-Wire DC Power Cable	67
2-13	Removing Hard Disk	68
2-14	Drive Skid Plate	69
2-15	Read/Write Board	69
2-16	P5 Connector	70
2-17	P8, P7, and P6 Connectors	70
2-18	P4 Connector	71
2-19	Removing Read/Write Board	71
2-20	DIP Shunt Location	72
2-21	Removing RD52 PCB	73
2-22	RD52 Jumper Options	74
2-23	Drive Skid Plate	75
2-24	Device Electronics Board	76
2-25	J4, J5, and J6 Connectors	77
2-26	Installing Connector	77
2-27	Device Electronics Board Configuration Components	78
2-28	16-Pin System Module Power Connector	79
2-29	4-Pin Mass Storage Device Power Connector	79
2-30	Power Supply Release Clips	80
2-31	Removing Power Supply Assembly	81
2-32	System Module (Rear)	81
2-33	I/O Option Boards	82

2-34	Diskette Drive I/O Cable and Hard Disk I/O Cables	83
2-35	Sliding Out Disk Drive Assemblies	83
2-36	Captive Screws on Chassis	84
2-37	System Module and 16-Pin Power Connector	85
2-38	Removing System Module	85
2-39	System ID PROM	86
2-40	Removing and Replacing ID PROM	87
2-41	Releasing Option EBO Board	88
2-42	Removing Option EBO Board	89
2-43	System Module and 2-Wire Battery Pack Cable	89
2-44	Removing Battery Pack	90
2-45	Cable Cover/Door	91
2-46	Cables Connected to I/O Board	92
2-47	I/O Board Handle	93
2-48	Turning I/O Board Handle	93
2-49	Sliding Out I/O Board	94
2-50	Removing Internal Cable	95
2-51	Shield Door Assembly	96
2-52	Telephone Line Interface (TLI)	97
2-53	Voice Unit	98
2-54	Removing Screws from Bottom of ADM ...	99
2-55	Removing Shield	100
2-56	ADM FRUs	100
2-57	Disconnecting Cables and Connector Strip	101
2-58	Replacing Power Supply	102
2-59	Disconnecting Cable from LED Board ...	103
2-60	Removing 5-Volt Jack	103
2-61	Removing LED Board	104
2-62	Disconnecting Cables from Motherboard	105
2-63	Removing Eight Hex-Nuts	105
2-64	Removing Motherboard	105
2-65	Disconnecting Cables from Digital I/O Board	107
2-66	Removing Digital I/O Board	107
2-67	Disconnecting Data Cable (on System Unit)	108
2-68	Removing Internal Data Cables	109
2-69	Removing Data Cable Connector Assembly	110
2-70	Removing Data Cable on Expander Box ...	111
2-71	Removing Cover Screws	112
2-72	Removing Cover from Expander Box	113

2-73	Releasing the Drive	113
2-74	Removing Optional Hard Disk Drive	114
2-75	Disconnecting Power Supply and Load Resistor Cables	115
2-76	Removing Mounting Screws	116
2-77	Power Supply/Load Resistor Assembly	117
2-78	Removing Internal SLU Option Cable	118
2-79	Unplugging Internal SLU Option Cable ...	119
2-80	SLU Option Cabling and Interconnect Boxes	120
2-81	Removing SLU Option Cable	121
3-1	Video Adjustment Locations	127
3-2	System Unit Power Switch	127
3-3	Monitor (Rear)	128
3-4	Tilt Mechanism Foot and Retaining Screw Cap	129
3-5	Retaining Screw	130
3-6	Removing Cover	131
3-7	Universal Alignment Pattern (Maintenance Services Version 2.0 and Lower)	133
3-8	Universal Alignment Pattern (Maintenance Services Version 2.0 and Higher)	133
3-9	Measuring the Screen Display	135
B-1	Professional 380 FRUs (Exploded View)	142
C-1	Functional Block Diagram	149

TABLES

1-1	No Response at Power-Up	16
1-2	Indicator Error Codes	17
1-3	Error Codes	21
1-4	Boot Problems	35
1-5	System Software Problems	36
1-6	Keyboard Problems	37
1-7	Printer Problems	38
1-8	Communications Problems	39
1-9	Diskette Problems	39
1-10	Digital Cable Connections	47
2-1	ADM Power Supply Cable Connections ...	101
2-2	Recommended Spares List	122

INTRODUCTION

PURPOSE

This pocket service guide describes the following topics for the Professional 380 system.

- Troubleshooting to the field replaceable unit (FRU)
- FRU removal and replacement
- Monochrome monitor adjustments

NOTES, CAUTIONS, AND WARNINGS

Notes, Cautions, and Warnings appear throughout the pocket service guide.

Notes contain general information you should know.

Cautions contain information to prevent damage to the equipment and software.

Warnings contain information to prevent personal injury.

TOOLS REQUIRED

You need the following tools to service the Professional 380 systems.

Tool	Part Number
Volt ohmmeter (VOM)	29-13510-00
1/4-inch slotted screwdriver	29-10983-00
Number 2 phillips screwdriver	29-11005-00
Keycap removal tool	74-27314-01
Hex-core alignment tool	29-23190-00
Video alignment template	29-24371-00
Color bar chart	29-24661-00
Screen cleaner	29-24791-00
ADM test box	70-22016-01
Static protection kit	29-11762-00

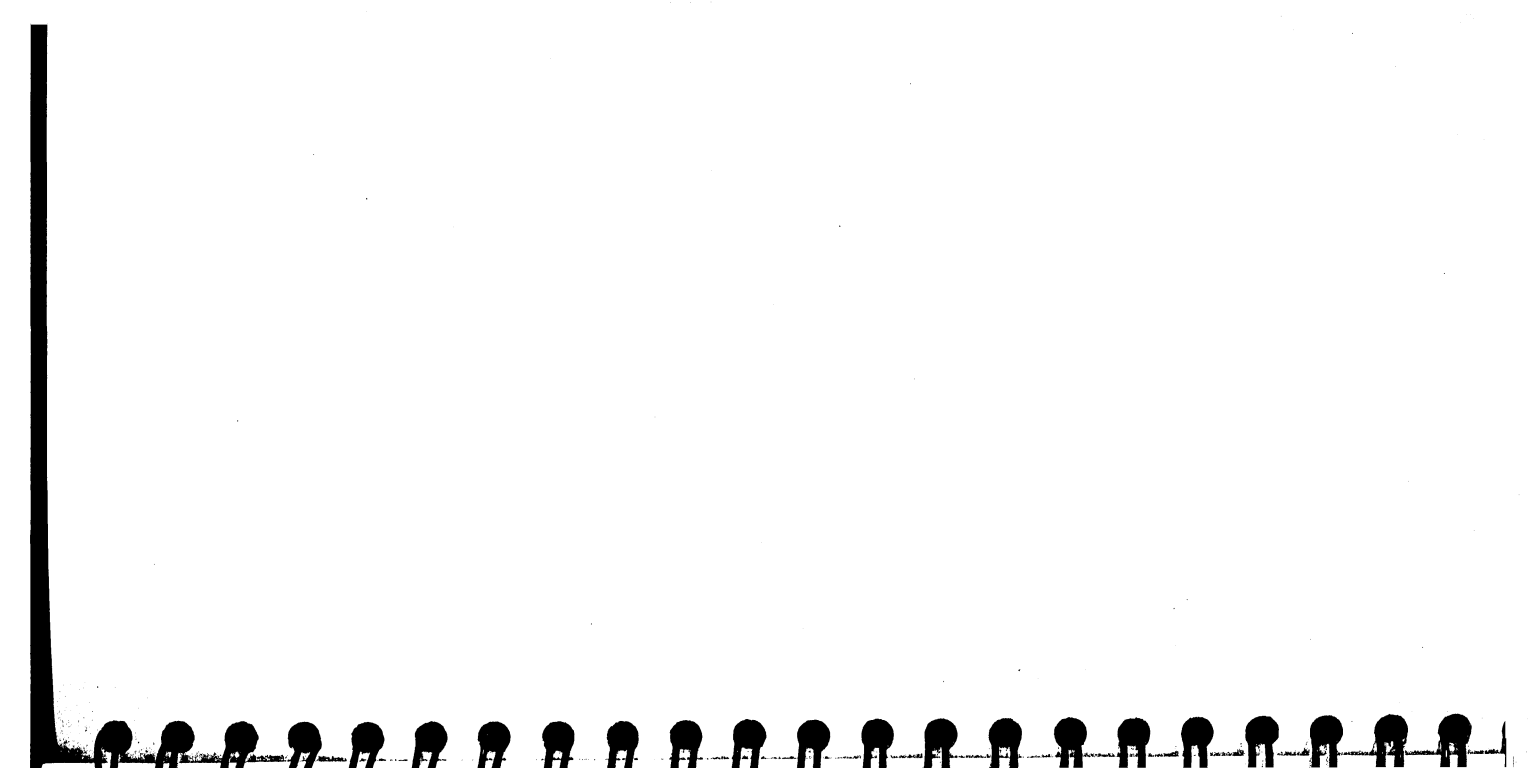

1 TROUBLESHOOTING AND TESTING

1.1 GENERAL

This chapter contains the information you need to troubleshoot the Professional 380 system and verify that the system is operating correctly. Troubleshooting the system is a two-part process using the internal self-test and the system maintenance application tests.

1.1.1 Troubleshooting Notes

The troubleshooting procedures in this guide are based on the assumption that only one field replaceable unit (FRU) has failed. The symptoms displayed on the monitor screen may indicate multiple failures. As a result, the symptoms may change as you replace FRUs. Always troubleshoot according to the current symptoms.

Spare parts can fail. Do not ignore the possibility of a part failure just because the part has been replaced once.

You must turn off power before disconnecting or replacing any FRU.

1.1.2 Physical Differences Between the Professional 380 and 325/350

The Professional 380 uses a diskette or hard disk based operating system. The Professional 380 has six slots available in the card cage for options. There are 18 openings on top of the card cage for top-mounted connectors. (There may be more than one hard disk controller.)

The Professional 350 can use a hard disk based operating system and also the diskette system. The 350 has three slots available in the card cage for options.

The Professional 325 uses a diskette based operating system and cannot use a hard disk. The 325 has only one slot available in the card cage for an option.

You can see the difference between the Professional 350, 325, or 380 system in the logo on the front panel by the power switch. If you open the card cage door on the system module you can see that a Professional 350 has six slots and a Professional 325 has four slots (slots one and three are blocked).

1.2 TROUBLESHOOTING WITH TESTS

The Professional computer has a series of internal power-up self-tests and diskettes that contain additional maintenance test programs. These tests help you isolate failures to the FRU. If a test indicates a failure, adjust or replace the FRU indicated by the test. When you adjust or replace an FRU, perform all the tests to ensure correct system operation.

1.3 POWER-UP SELF-TEST

The Professional computer has an internal power-up self-test that checks all major system components. The self-test also determines what options are present and if each option can operate correctly. The self-test runs automatically every time you turn on system power.

The results of the power-up self-test appear as a graphic display on the screen. These displays let you quickly identify power-up problems. Figure 1-1 shows these displays and directs you to the correct troubleshooting procedure.

CAUTION

Turn off or disconnect any equipment attached to the real-time interface, if installed, before you turn on the system. Let the power-up self-test run to completion before you turn on the equipment attached to the real-time interface.

1.4 MAINTENANCE SERVICES TESTS

The Professional system comes with a maintenance diskette package. This maintenance application package contains a complete set of test programs. You can run the diskettes as an application on the diskette based operating system. Press the **Help** key for information about maintenance services and the tests.

NOTE

The Help key describes the selected test, while the Do, Enter, and Return keys execute the test.

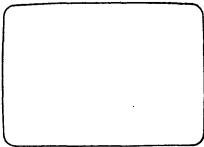

BLANK SCREEN SEE PARAGRAPH 1.5

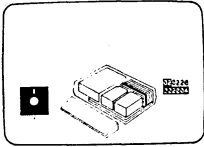

SYSTEM IMAGE WITH HIGHLIGHT AND FLOPPY SEE PARAGRAPH 1.6

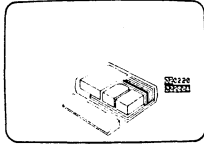

SYSTEM IMAGE WITH HIGHLIGHT SEE PARAGRAPH 1.7

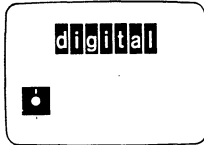

DIGITAL LOGO AND FLOPPY IMAGE SEE PARAGRAPH 1.8

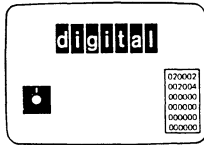

DIGITAL LOGO WITH NUMBERS AND FLOPPY SEE PARAGRAPH 1.8.1

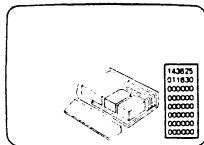

SYSTEM IMAGE WITH NO HIGHLIGHTS SEE PARAGRAPH 1.9



DIGITAL LOGO
 SYSTEM CHECKS GOOD. IF THERE IS NO BOOT AFTER ABOUT 2 MINUTES. SEE PARAGRAPH 1.8. RUN THE SYSTEM MAINTENANCE DISKETTE. SEE PARAGRAPH 1.4 FOR INSTRUCTIONS.

MA-0001A-83

Figure 1-1 Power-Up Troubleshooting Diagram

1.4.1 Running the Maintenance Application Diskettes

You can run the maintenance application diskettes on a diskette-based system with the following procedure. The diskette runs only on the Professional diskette-based operating system (P/OS).

NOTE

If you are servicing a Professional 300 computer without mass storage that loads its operating system from a central file server, you must first install a diskette drive and controller. Refer to Paragraph 2.4, RX50 Diskette Drive, and Paragraph 2.12, I/O Boards, for removal and replacement instructions.

CAUTION

Turn off or disconnect all equipment attached to the real-time interface, if installed, before you run tests. Let the tests run to completion before you turn on the equipment attached to the real-time interface.

1. Turn power off.
2. Remove any diskette(s) in the drives.
3. Insert the P/OS system diskette in drive 1.
4. Turn power on.
5. At the prompt, insert the PRO Installation/Maintenance Application diskette in drive 1 and the PRO Installation/Maintenance Application diskette number 2 in drive 2, then press **Resume**.
6. Select monitor type (maintenance services version 3.0 and higher).
7. Select the test(s) you want to run.

1.4.2 Customer Mode and Service Mode

You can use the maintenance application diskette in two modes, customer and service. In customer mode, the screen display lists the following eight tests and programs.

```
System unit test
Keyboard test
Printer test
Configuration display program
Bar pattern program
Update maintenance services
Bigdisk block check
Minidisk block check
```

The system always enters customer mode when you select the maintenance services menu.

Service mode lets you run all or part of the system unit test. You can also repeat each test automatically. In service mode, the screen display lists the following 10 tests and programs.

```
System unit test
Keyboard test
Printer test
Configuration display program
Bar pattern program
Video alignment pattern program
Update maintenance services
Bigdisk block check
Minidisk block check
RX speed test
Hard disk formatter
```

The system enters service mode only after you type the correct key sequence on the keyboard.

The following paragraphs describe the use of each test in both modes. The keyboard key test, printer test, and bar pattern program are the same for both modes. The update maintenance services program lets you add test programs for new options; it is the same in both modes. The video alignment pattern program works only in service mode.

NOTE

Beginning with maintenance services version 3.0, displayable menu selections are dynamic. This means that if functionality does not exist to run specific maintenance services selections, those selections do not appear in the menu. For example, a system without a hard disk does not display a big disk block check or a fast formatter. Also, the system unit test submenu (Field Service mode) does not show a hard disk subsystem.

1.4.3 System Unit Test

The system unit test is a general test for all system unit components. The system unit test has the following six sections.

Diskette drive checks the drive read/write circuits.

Hard disk checks the drive read/write circuits. This test is only for systems with a hard disk drive.

Printer port internally loops back the system printer circuits. This test does not send data to the printer.

Floating point processor checks the floating point instruction set.

Communications port internally loops back the system communications circuits. This test does not send or receive data from external devices.

All other options tests each option connected to the system and those options that have had their test added with the update maintenance services program.

The system unit test works in customer and service mode.

1.4.3.1 Running the System Unit Test in Customer Mode – Run the system unit test in customer mode as follows.

1. Select the maintenance services menu.
2. When the maintenance services menu appears on the screen, select the system unit test with the cursor keys.
3. Press the **Do** key.
4. The test runs for about 2-1/2 minutes. While the test is running, the following message appears on the screen.

SYSTEM UNIT UNDER TEST

XX

In the upper-left corner the word **working** flashes. As the test runs, the number **XX** counts down to 0.

5. A test summary appears at the end of the test.
6. Press the **Help** key for more information about any failures that occurred.

1.4.3.2 Running the System Unit Test in Service Mode – Run the system unit test in service mode as follows.

1. Select the maintenance services menu.
2. Press the **F12**, **F19**, and **F5** keys in that sequence. This places the test in service mode.
3. When the maintenance services menu appears on the screen, select the system unit test with the cursor keys. Press **Do**.

4. Select the test or tests you want to run. If you want to run loopback tests, make sure the printer and communications port loopback connectors are both installed before running that test. Press **Select**.

NOTE

Selecting "Loopback connectors installed" only puts the ports on back of the unit in external loopback mode. Selecting only this menu item and pressing **Do** will not test anything.

NOTE

Individual system option tests appear on the menu only if that option is in the system, and its test has been added with the update maintenance services program. Refer to Paragraph 1.15 for information about tests for specific options.

5. From the new display, select either a single or multiple test pass. If you select multiple passes, press **Interrupt** and **Do** to stop the test. Make at least two complete passes for accurate results. While the test is running, a summary of the components being tested and their current status appears on the screen.

1.4.3.3 System Unit Test Results – The system unit test displays its results on the screen. Press **Help** for more information and corrective action you can take if errors have occurred. Press **Exit** to return to the maintenance services menu.

1.4.4 Keyboard Test

The keyboard test lets you verify that each key on the keyboard is working correctly.

NOTE

For this test to operate correctly, the keyboard must be set for United States/Canada (LK201-AA). If you have a different setting, first enter set-up mode (press **Set-Up**), move the cursor to "Change Keyboard," and press **Do**. Remember to return the correct setting to your keyboard when you finish. (Version 3.0 and higher automatically does this.)

1.4.4.1 Running the Keyboard Test – Run the keyboard test as follows. The keyboard test is the same in customer and service mode.

1. Select the keyboard test with the cursor keys.
2. Press **Do**.
3. Wait about five seconds for the keyboard diagram to appear on the screen.
4. Press each key on the keyboard at least twice. The first time you press a key, the corresponding key on the diagram should change color. The second time you press a key, the key should return to the original color.

NOTE

You cannot test keys marked X.

5. Press **Exit** five consecutive times to end the program and return to the maintenance services menu.

1.4.4.2 Keyboard Test Results – The keyboard diagram tells you if a key has failed. The test indicates a key failure when you press a key and the corresponding key on the diagram does not change color. If the test finds a bad key, replace the keyboard.

1.4.5 Printer Test

The printer test lets you send data to the printer.

1.4.5.1 Running the Printer Test – Run the printer test as follows. The printer test is the same in customer and service mode.

1. Make sure printer power is on and the controls are set to match the system. Refer to the printer's pocket service guide for information on the controls.
2. Select the printer test with the cursor keys.
3. Press **Do**.
4. Wait about 15 seconds for the test to print a short pattern on the printer and the screen. The pattern is less than a page long.
5. Press **Resume** to return to the maintenance services menu.

1.4.5.2 Printer Test Results – The pattern on the screen should match the pattern printed on the printer. Refer to Paragraph 1.11 if the printer does not print the same pattern or does not print at all.

1.4.6 Configuration Display Program

The configuration display program lists the components connected to the system. Use the configuration display program to determine what modules are connected to the system, the system identification (ID) number, and service information. This test works in customer and service mode. However, in service mode, this test shows additional data.

1.4.6.1 Running the Configuration Display Program in Customer Mode – Run the configuration display program in customer mode as follows.

1. Select the configuration display program with the cursor keys.
2. Press **Do**.
3. Wait about eight seconds for the screen display. (See the following example.)
4. Press **Resume** to return to the maintenance services menu.

Typical Screen Display*

Identification number: 000000155069
 Duty Cycle Start Date: 1 Jul 84
Cumulative P/OS Run Time: 954 hours

System Module:

Keyboard interface	J-11 Processor
Communication interface management	Memory
Printer interface adapter	Floating point
Clock and EBO	On-board video
512 Kilobytes of memory (system total)	
Option slot 1: Hard disk x megabyte -- <u>(xxxx read/writes)</u>	
Option slot 2: Diskette controller -- <u>(xxxxx read/writes)</u>	
Option slot 3: EMPTY	
Option slot 4: EMPTY	
Option slot 5: EMPTY	
Option slot 6: EMPTY	
Keyboard LK201 -- <u>(xxxxx key strokes)</u>	

* The underlined information appears only in service mode.

“Identification number” is the system ID or identification number. This number resides in the removable ID PROM.

“Duty Cycle Start Date” and “Cumulative P/OS Run Time” appear only in service mode and only if the duty cycle was set. Refer to Paragraph 1.4.6.2.

“System Module” lists all standard and optional equipment connected to the system module. In this case, the system has the standard printer, communications, video controller with extended bit map option, and keyboard interfaces; processor; memory management; and clock. The floating point and 512K bytes of memory are also in the system.

“Option Slot” lists the boards connected to the system along with the location of each board. The number of read/writes performed by the disk drives appears only in service mode.

“Keyboard” shows the type of keyboard connected to the system. The number of keystrokes appears only in service mode. If it is available, DECTouch is also displayed (version 3.0 and higher).

1.4.6.2 Running the Configuration Display Program in Service Mode – Run the configuration display program in service mode as follows.

1. Select the maintenance services menu.
2. Press **F12**, **F19**, and **F5** in that sequence. This places the program in service mode.
3. When the maintenance services menu appears on the screen, select the configuration display program with the cursor keys. Press **Do**.
4. Press **Resume** to return to the maintenance menu or press **F20** to set or reset the duty cycle start date.

NOTE

Pressing **F20** erases all present duty cycle data.

NOTE

If testing a color monitor, you must select “Color monitor” in set-up mode before running maintenance services (version 2.0 or lower).

1.4.7 Bar Pattern Program

The bar pattern program lets you place a bar pattern on the screen. Use this program to adjust the operator monitor controls. This program works with black-and-white (monochrome) and color monitors.

The bar pattern is made up of eight bars. Each bar is a different color or shade of grey. If you have a color monitor, the colors are as follows (from left to right).

(dark)								(light)
Black	Blue	Red	Magenta	Green	Cyan	Yellow	White	

NOTE

You must have an extended bit map option installed to use this program.

1.4.7.1 Running the Bar Pattern Program – Run the bar pattern program as follows.

1. Select the bar pattern program with the cursor keys.
2. Press **Do**.
3. Wait for the bar pattern to appear on the screen. This takes about five seconds.
4. Adjust the operator monitor controls.
5. Press **Resume** to return to the main menu.

1.4.7.2 Bar Pattern Program Results – The bar pattern program is not a test. This program helps you adjust your monitor for the best possible screen display.

1.4.8 Video Alignment Pattern Program

The video alignment pattern program runs only in service mode and places another menu on the screen. You can select the universal alignment pattern to align black-and-white (monochrome) and color monitors. The alignment pattern program also lets you select red, green, or blue screens to make color monitor adjustments (an extended bit map option must be present for color), or a white screen to check purity.

1.4.8.1 Running the Alignment Pattern Program – Run the alignment pattern program as follows. This program works only in service mode.

1. Select the maintenance services menu.
2. Press **F12**, **F19**, and **F5** in that sequence. This places the program in service mode.
3. When the maintenance services menu appears on the screen, select alignment patterns with the cursor keys. Press **Do**.
4. Select the desired pattern. Press **Do**.
5. Press **Resume** to return to the alignment pattern menu.

1.4.9 Update Maintenance Services

A software diagnostic diskette is shipped with most options. This diskette contains software that runs as part of the system unit test supplied with maintenance services. You must first use the update maintenance services program to make this software a part of the system unit test. The update program physically installs these other tests on maintenance services diskette 2.

Update the system unit test to include an option's diagnostics as follows.

NOTE

The update procedure must be done only once. After you update the system unit test, the option's diagnostics run every time the system unit test is run.

1. Boot the system with the P/OS system diskette.
2. When prompted to load an application program, remove the P/OS system diskette and place the maintenance services application diskette in drive 1 and press **Resume**.
3. When prompted, insert maintenance services diskette 2 in drive 2 and press **Resume**.
4. Select "Update Maintenance Services" from the maintenance services menu. Press **Do**. When prompted, place the option's diagnostic diskette in drive 2. Follow the directions on the screen.

1.4.10 Bigdisk Block Check

The bigdisk block check test determines if there are new bad blocks on the hard disk. It only runs if P/OS is installed on the hard disk.

The test reads data; it does not write data, so no data will be destroyed.

NOTE

If the test fails, back up all important customer files before reinstalling P/OS. If you do not back up files before reinstalling P/OS, the customer will lose data.

The test is the same in customer and service modes, although the screen display for the results is different.

In customer mode, the results summary tells you if no corrupt blocks have been found, or if new corrupt blocks have been found and P/OS must be reinstalled to update the P/OS bad block file. Press **Help** for more information.

In service mode, the screen displays:

FOUND ON HEAD:	0	1	2	3
P/OS BAD BLOCK FILE:	XX	XX	XX	XX
NEW CORRUPT BLOCKS:	XX	XX	XX	XX

If new corrupt blocks are found on any head, run the test at least two more times to make sure the results are consistent. If the disk is corrupt, back up files and reinstall P/OS. If the results are inconsistent, the fault may be in the hard disk drive controller or the read/write module within the drive.

1.4.11 Minidisk Block Check

The minidisk block check test determines if there are new bad blocks on a diskette. It only runs on P/OS initialized diskettes.

The test reads data; it does not write data, so no data will be destroyed.

NOTE

If the test fails, back up all important customer files before reinitializing the diskette. If you do not back up files before reinitializing the diskette, the customer will lose data.

The test is the same in customer and service modes, although the screen display for the results is different. In customer mode, the results summary tells you if no corrupt blocks have been found, or if new corrupt blocks have been found and the diskette must be reinitialized to update the bad block file. Press **Help** for more information.

In service mode, the screen displays:

NUMBER OF BAD BLOCKS IN P/OS BAD BLOCK FILE	NUMBER OF NEW CORRUPT/BAD BLOCKS FOUND
XX	XX

If new corrupt blocks are found, run the test at least two more times to make sure the results are consistent. If the diskette is corrupt, back up files and reinitialize the diskette. If the results are inconsistent, the fault may be in the RX controller or the drive.

1.4.12 RX Speed Test

The RX speed test is a routine that checks the diskette drive spindle motor speed to make sure the drive speed is in tolerance. This test runs in service mode only. If the RX controller is below the correct revision to run this test, the following message appears.

Your Floppy Drive Controller Does not
Support This Function

NOTE

This message does not mean there is a failure in the system. It means the RX controller is not at the revision level necessary to run the test.

If the RX controller is at the correct revision level to run this test, the following message appears.

RX SPEED TEST
+/- X.XX
CURRENT SPEED

Run this test for five minutes before you record the sample speed. If the sample speed is greater than +1.00 or less than -1.00, the drive speed is out of tolerance. You must replace the floppy diskette drive.

1.4.13 Fast Formatter

To run the fast formatter, do the following.

1. Select the maintenance services menu.
2. Press **F12**, **F19**, and **F5** in that order. This places the program in service mode.
3. When the maintenance services menu appears on the screen, select the hard disk formatter with the cursor. Press **Do**.
4. Select the hard disk subsystem you want to format. The subsystems are numbered in the submenu (if more than one hard disk subsystem exists). The submenu numbers correspond to the physical location of the hard disk controllers on the CTI bus. For example, hard disk subsystem number 1 refers to the subsystem physically located in the lowest numbered slot. Hard disk subsystem number 2 refers to the subsystem physically located in the next lowest numbered slot, and so on.
5. While the test is running, the following message appears on the screen.

```

      FORMATTING (in reverse video and flashing)
      FAST FORMATTER
      
```
6. The following message appears on the screen during program verification.

```

      VERIFYING (reading) (in reverse video and
      flashing)
      FAST FORMATTER
      
```
7. The final screen appears as follows.

```

      Hard Disk: x.x Mb formatted

      FAST FORMAT has completed successfully

      Press EXIT or MAIN SCREEN to return to
      the Maintenance Services Main Menu.
      
```

1.5 NO RESPONSE AT POWER-UP

If the screen remains blank for more than two minutes, restart the system by turning the system power switch off and on.

Use Table 1-1 and the indicators on back of the system unit to troubleshoot this problem. Table 1-2 lists the indicator error codes and related FRUs.

Table 1-1 No Response at Power-Up

Symptom	Additional Checks	Corrective Action
No response when power switch is turned on	Check power cord connection to system and wall outlet.	Reconnect power cord to system and wall outlet.
	Circuit breaker tripped.	Reset circuit breaker by pushing it in.
	No power at wall outlet.	Check power with your VOM.
	Power cord shorted or opened.	Check power cord for continuity with your VOM and replace if needed.
No response when power switch is turned on, but fan is running		Check power cable connection from power supply to system module.
	Green indicator on back of system unit is off.	Check power cable connection from power supply to system module. Replace system power supply.
	Green indicator is on and four red indicators are off.	Check monitor cable connections and adjust monitor controls. Reseat system daughter boards, if present.
	Green indicator is on and any or all of red indicators are on.	Replace monitor. System has failed. Refer to Table 1-2 for the indicator error and related FRU.

Table 1-2 Indicator Error Codes

Indicator*				Error	Corrective Action
4	3	2	1		
○	○	○	○	None (test passed)	<ol style="list-style-type: none"> 1. Adjust contrast and brightness controls on monitor. 2. Check video cable connections at monitor. 3. Check video alignment (Chapter 3). 4. Replace monitor. 5. Replace system module.
○	○	○	●	I/O	<ol style="list-style-type: none"> 1. Check all cables connected to I/O board in slot 1. 2. Reseat I/O board in slot 1. 3. Replace I/O board in slot 1. 4. Replace device connected to I/O board in slot 1.
○	○	●	○	I/O	<ol style="list-style-type: none"> 1. Check all cables connected to I/O board in slot 2. 2. Reseat I/O board in slot 2. 3. Replace I/O board in slot 2. 4. Replace device connected to I/O board in slot 2.
○	○	●	●	I/O	<ol style="list-style-type: none"> 1. Check all cables connected to I/O board in slot 3. 2. Reseat I/O board in slot 3. 3. Replace I/O board in slot 3. 4. Replace device connected to I/O board in slot 3.
○	●	○	○	I/O	<ol style="list-style-type: none"> 1. Check all cables connected to I/O board in slot 4. 2. Reseat I/O board in slot 4. 3. Replace I/O board in slot 4. 4. Replace device connected to I/O board in slot 4.
○	●	○	●	I/O	<ol style="list-style-type: none"> 1. Check all cables connected to I/O board in slot 5. 2. Reseat I/O board in slot 5. 3. Replace I/O board in slot 5. 4. Replace device connected to I/O board in slot 5.
○	●	●	○	I/O	<ol style="list-style-type: none"> 1. Check all cables connected to I/O board in slot 6. 2. Reseat I/O board in slot 6. 3. Replace I/O board in slot 6. 4. Replace device connected to I/O board in slot 6.

* A ● means indicator is on.

Table 1-2 Indicator Error Codes (Cont)

Indicator*				Error	Corrective Action
4	3	2	1		
○	●	●	●	System	<ol style="list-style-type: none"> 1. Restart system by turning system power switch off and on. 2. If error disappears, run system unit test on maintenance application diskette. 3. If error remains, replace system module.
●	○	○	○	System	<ol style="list-style-type: none"> 1. Restart system by turning system power switch off and on. 2. If error disappears, run system unit test on maintenance application diskette. 3. If error remains, replace system module.
●	○	○	●	Keyboard	<ol style="list-style-type: none"> 1. Check keyboard cable and connections at keyboard and monitor. 2. Check video cable at monitor and system unit. Right angle end of cable should be connected to video monitor. 3. Replace keyboard. 4. Replace monitor. 5. Replace system board.
●	○	●	○	No boot	<ol style="list-style-type: none"> 1. Reboot from P/OS system diskette. 2. If reboot is good, check RD hard disk subsystem. 3. If still no boot, check for bad diskette. 4. Check cables on RX50 and RD hard disk subsystems from the controller(s) to their drives. 5. Replace system module. 6. Refer to Paragraph 1.8.
●	○	●	●	Monitor not present	<ol style="list-style-type: none"> 1. Check video cable and connections at monitor and system unit. Right angle end of cable should be connected to video monitor. 2. Replace monitor. 3. Replace system module.

Table 1-2 Indicator Error Codes (Cont)

Indicator*				Error	Corrective Action
4	3	2	1		
●	●	○	○	System	<ol style="list-style-type: none"> 1. Restart system by turning system power switch off and on. 2. If error disappears, run system unit test on maintenance application diskette. 3. If error remains, replace system module.
●	●	○	●	Extended bit map daughter board	<ol style="list-style-type: none"> 1. Restart system by turning system power switch off and on. 2. If error disappears, run system unit test on maintenance application diskette. 3. If error remains, replace EBO daughter card. 4. If error remains, replace system module.
●	●	●	○	Memory daughter board	<ol style="list-style-type: none"> 1. Restart system by turning system power switch off and on. 2. If error disappears, run system unit test on maintenance application diskette. 3. If error remains, replace memory daughter card. 4. If error remains, replace system module.
●	●	●	●	System	<ol style="list-style-type: none"> 1. Restart system by turning system power switch off and on. 2. If error remains, replace memory daughter board, if present. 3. If error remains, replace system module. 4. If error still remains, remove option boards one at a time until error changes. Replace last board removed when error changes.

* A ● means indicator is on.

1.6 SYSTEM AND BOOT PROBLEMS

The system image with highlight and floppy display means the power-up self-test found a problem and the system cannot boot. Troubleshoot this problem as a system error. Refer to Paragraph 1.7.

1.7 SYSTEM FAILURE WITH BOOT

The system image with highlight only display means the power-up self-test found a problem, but the system boot-ed. To troubleshoot, find the identification (ID) number and error code in the message. Figure 1-2 shows the location of the codes. Table 1-3 lists each ID number, the error code(s) for that ID, and the corrective action to take.

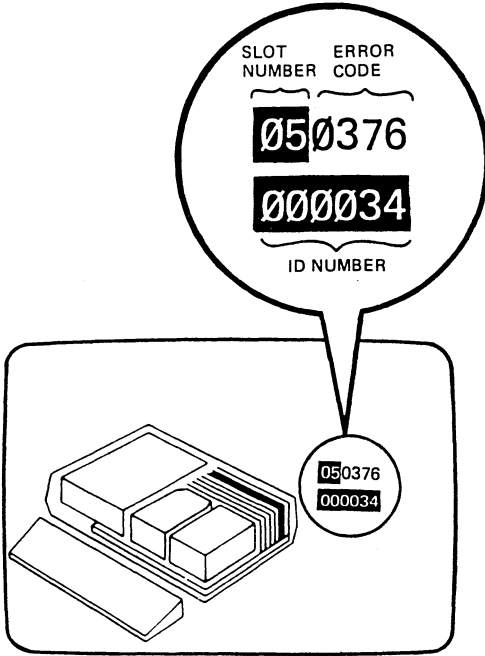

MA-0002-82A

Figure 1-2 Self-Test Diagram

Table 1-3 Error Codes

ID Number	Error Code	Problem Area	Corrective Action
Any ID	0374	Slot shown on screen	<ol style="list-style-type: none"> 1. Reseat board in slot shown on screen. 2. Replace board in slot shown on screen. 3. Replace system module.
Any ID	0376	Slot shown on screen	Replace board in slot shown on screen.
00001	0060	Keyboard	Replace keyboard.
	075	Keyboard	<ol style="list-style-type: none"> 1. Run keyboard key test. 2. Replace keyboard.
	0076	Keyboard	Replace keyboard.
000014	Any code	Keyboard port	Replace system module.
000017	Any code	Printer port	Replace system module.
000021	Any code	Communications port	Replace system module.
000023	Any code	Time of day	Replace system module.
000024	Any code	Nonvolatile RAM	Replace system module.
000025	Any code	Interrupts	<ol style="list-style-type: none"> 1. Disconnect any devices from COMM1 and PTR1 connectors. 2. Turn power on. If failure goes away, problem is with an attached device. If failure remains, go to step 3. 3. Remove all options. 4. Turn power back on. 5. If fails again, replace system module. 6. If failure goes away, install each option one at a time until symptom reappears. Replace last board inserted.
000034	0002	Memory module	Memory exceeds 3 megabytes. Remove memory modules until no error.
	Any code	Memory module (in card cage)	Replace board in slot shown on screen.

Table 1-3 Error Codes (Cont)

ID Number	Error Code	Problem Area	Corrective Action
000041 (See Notes 1 and 2 at end of table)	0001	DTMF loopback failure	Replace TMS controller.
	0002	CODEC loopback failure	Replace TMS controller.
	0003	DTMF loopback and CODEC loopback failure	Replace TMS controller.
	0004	Dial tone detect failure	Replace TMS controller.
	0005	Dial tone detect and DTMF loopback failure	Replace TMS controller.
	0006	Dial tone detect and CODEC loopback failure	Replace TMS controller.
	0007	Dial tone detect, CODEC loopback, and DTMF loopback failure	Replace TMS controller.
	0010	7910 modem analog loopback failure	Replace TMS controller.
	0011	7910 modem analog loopback and DTMF loopback failure	Replace TMS controller.
	0012	7910 modem analog loopback and CODEC loopback failure	Replace TMS controller.
	0013	7910 modem analog loopback, CODEC loopback and DTMF loopback failure	Replace TMS controller.
	0014	7910 modem analog loopback and dial tone detect failure	Replace TMS controller.

Table 1-3 Error Codes (Cont)

ID Number	Error Code	Problem Area	Corrective Action
	0015	7910 modem analog loopback, dial tone detect, and DTMF loopback failure	Replace TMS controller.
	0016	7910 modem analog loopback, dial tone detect, and CODEC loopback failure	Replace TMS controller.
	0017	7910 modem analog loopback, dial tone detect, CODEC loopback, and DTMF loopback failure	Replace TMS controller.
	0020	Modem analog loopback failure	Replace TMS controller.
	0021	Modem analog loopback and DTMF loopback failure	1. Replace TLI. 2. Replace TMS controller.
	0022	Modem analog loopback and CODEC loopback failure	Replace TMS controller.
	0023	Modem analog loopback, CODEC loopback, and DTMF loopback failure	Replace TMS controller.
	0024	Modem analog loopback and dial tone detect failure	Replace TMS controller.
	0025	Modem analog loopback, dial tone detect, and DTMF loopback failure	Replace TMS controller.
	0026	Modem analog loopback, dial tone detect, and CODEC loopback failure	Replace TMS controller.

Table 1-3 Error Codes (Cont)

ID Number	Error Code	Problem Area	Corrective Action
0027		Modem analog loopback, dial tone detect, CODEC loopback, and DTMF loopback failure	Replace TMS controller.
0030		Modem analog loopback and 7910 modem analog loopback failure	Replace TMS controller.
0031		Modem analog loopback, 7910 modem analog loopback, and DTMF loopback failure	1. Replace TLI. 2. Replace TMS controller.
0032		Modem analog loopback, 7910 modem analog loopback, and CODEC loopback failure	Replace TMS controller.
0033		Modem analog loopback, 7910 modem analog loopback, CODEC loopback, and DTMF loopback failure	Replace TMS controller.
0034		Modem analog loopback, 7910 modem analog loopback, and dial tone detect failure	Replace TMS controller.
0035		Modem analog loopback, 7910 modem analog loopback, dial tone detect, and DTMF loopback failure	Replace TMS controller.

Table 1-3 Error Codes (Cont)

ID Number	Error Code	Problem Area	Corrective Action
0036		Modem analog loopback, 7910 modem analog loopback, dial tone detect, and CODEC loopback failure	Replace TMS controller.
0037		Modem analog loopback, 7910 modem analog loopback, dial tone detect, CODEC loopback, and DTMF loopback failure	Replace TMS controller.
0040		VU status request failure	<ol style="list-style-type: none"> 1. Replace voice unit. 2. Replace TLI. 3. Replace TMS controller.
0041		VU status request and DTMF loopback failure	Replace TMS controller and voice unit.
0042		VU status request and CODEC loopback failure	Replace TMS controller and voice unit.
0043		VU status request, CODEC loopback, and DTMF loopback, failure	Replace TMS controller and voice unit.
0044		VU status request and dial tone detect failure	Replace TMS controller and voice unit.
0045		VU status request, dial tone detect, and DTMF loopback failure	Replace TMS controller and voice unit.
0046		VU status request, dial tone detect, and CODEC loopback failure	Replace TMS controller and voice unit.

Table 1-3 Error Codes (Cont)

ID Number	Error Code	Problem Area	Corrective Action
	0047	VU status request, dial tone detect, CODEC loopback, and DTMF loopback failure	Replace TMS controller and voice unit.
	0050	VU status request and 7910 modem analog loopback failure	Replace TMS controller and voice unit.
	0051	VU status request, 7910 modem analog loopback, and DTMF loopback failure	Replace TMS controller and voice unit.
	0052	VU status request, 7910 modem analog loopback, and CODEC loopback failure	Replace TMS controller and voice unit.
	0053	VU status request, 7910 modem analog loopback, CODEC loopback, and DTMF loopback failure	Replace TMS controller and voice unit.
	0054	VU status request, 7910 modem analog loopback, and dial tone detect failure	Replace TMS controller and voice unit.
	0055	VU status request, 7910 modem analog loopback, dial tone detect, and DTMF loopback failure	Replace TMS controller and voice unit.

Table 1-3 Error Codes (Cont)

ID Number	Error Code	Problem Area	Corrective Action
0056	VU status request, 7910	modem analog loopback, dial tone detect, and CODEC loopback failure	Replace TMS controller and voice unit.
0057	VU status request, 7910	modem analog loopback, dial tone detect, CODEC loopback, and DTMF loopback failure	Replace TMS controller and voice unit.
0060	VU status request and modem analog loopback failure		Replace TMS controller and voice unit.
0061	VU status request, modem analog loopback, and DTMF loopback failure		<ol style="list-style-type: none"> 1. Replace TLI and voice unit. 2. Replace TMS controller.
0062	VU status request, modem analog loopback, and CODEC loopback failure		Replace TMS controller and voice unit.
0063	VU status request, modem analog loopback, CODEC loopback, and DTMF loopback failure		Replace TMS controller and voice unit.
0064	VU status request, modem analog loopback, and dial tone detect failure		Replace TMS controller and voice unit.
0065	VU status request, modem analog loopback, dial tone detect, and DTMF loopback failure		Replace TMS controller and voice unit.

Table 1-3 Error Codes (Cont)

ID Number	Error Code	Problem Area	Corrective Action
0067		VU status request, modem analog loopback, dial tone detect, CODEC loopback, and DTMF loopback failure	Replace TMS controller and voice unit.
0070		VU status request, modem analog loopback, and 7910 modem analog loopback failure	Replace TMS controller and voice unit.
0071		VU status request, modem analog loopback, 7910 modem analog loopback, and DTMF loopback failure	<ol style="list-style-type: none"> 1. Replace TLI and voice unit. 2. Replace TMS controller.
0072		VU status request, modem analog loopback, 7910 modem analog loopback, and loopback failure	Replace TMS controller and voice unit.
0073		VU status request, modem analog loopback, 7910 modem analog loopback, CODEC loopback, and DTMF loopback failure	Replace TMS controller and voice unit.
0074		VU status request, modem analog loopback, 7910 modem analog loopback, and dial tone detect failure	Replace TMS controller and voice unit.

Table 1-3 Error Codes (Cont)

ID Number	Error Code	Problem Area	Corrective Action
	0075	VU status request, modem analog loopback, 7910 modem analog loopback, dial tone detect, and DTMF loopback failure	Replace TMS controller and voice unit.
	0076	VU status request, modem analog loopback, 7910 modem analog loopback, dial tone detect, and CODEC loopback failure	Replace TMS controller and voice unit.
	0077	VU status request, modem analog loopback, 7910 modem analog loopback, dial tone detect, CODEC loopback, and DTMF loopback failure	Replace TMS controller and voice unit.
	0201	ROM failure	Replace TMS controller.
	0202	RAM failure	Replace TMS controller
	0204	Fraudulent	Replace TMS controller.
	0210	Interrupt failure – acknowledge now	Replace TMS controller.
	0220	Interrupt failure – kill	Replace TMS controller.
000042	0110 or less	DECNA module	1. Replace DECNA module. 2. Replace system module.
	0111 or more		1. Test network hardware (Paragraph 1.15.4).
000043	Any code	CP/M module	1. Replace board in slot shown on screen.

Table 1-3 Error Codes (Cont)

ID Number	Error Code	Problem Area	Corrective Action
000046	0001	Real-time interface (RTI) – serial line unit 1	<ol style="list-style-type: none"> 1. Reseat cables and board in slot 6. 2. Replace module in slot 6.
CAUTION			
Turn off all devices attached to RTI cables before turning system on again.			
	0002	RTI – serial line unit 2	<ol style="list-style-type: none"> 1. Reseat cables and board in slot 6. 2. Replace module in slot 6.
	0003	RTI – parallel I/O	<ol style="list-style-type: none"> 1. Reseat cables and board in slot 6. 2. Replace module in slot 6.
	0004	RTI – IEEE port	<ol style="list-style-type: none"> 1. Reseat cables and board in slot 6. 2. Replace module in slot 6.
	0005	RTI – interrupt logic	<ol style="list-style-type: none"> 1. Reseat cables and board in slot 6. 2. Replace module in slot 6.
000050	0002 thru 0007	PC380 base video failure	<ol style="list-style-type: none"> 1. Replace system module.
	0103 0106 0107	PC380 EBO plane 2 failure	<ol style="list-style-type: none"> 1. Replace EBO daughter module. 2. Replace system module.
	0203 0206 0207	PC380 EBO plane 3 failure	<ol style="list-style-type: none"> 1. Replace EBO daughter module. 2. Replace system module.
000064	0001 0002	Port 0	For all port problems.
	0003	Port 0	<ol style="list-style-type: none"> 1. Replace SLU option module.
	0003	Port 1	<ol style="list-style-type: none"> 2. Replace SLU interconnect box
	0004	Port 1	<ol style="list-style-type: none"> 3. Replace SLU option cable.
	0005	Port 2	
	0006	Port 2	
	0007	Port 3	
	0010	Port 3	
	0020 0025	SLU module	<ol style="list-style-type: none"> 1. Replace SLU module. 2. Replace system module.

Table 1-3 Error Codes (Cont)

ID Number	Error Code	Problem Area	Corrective Action
	0030	SLU module	1. Replace SLU module.
	0040		2. Replace system module.
	0100	Port 0	For all port problems.
	0102	Port 0	1. Disconnect device
	0120	Port 1	attached to port
	0140	Port 2	and retry. If problem
	0142	Port 2	goes away, device is at
			fault. If problem remains,
	0142	Port 2	go to step 2.
	0160	Port 3	2. Replace SLU option
			module.
	0162	Port 3	3. Replace SLU intercon-
			nect box.
			4. Replace SLU option
			cable.
			5. Check software.
000401	0001		1. Check cables.
	Any		2. Replace board in slot
	code		shown on screen.
			3. Replace RD hard disk
			drive. Verify that
			either the read/write
			board or complete disk
			drive failed.
	0013	RD subsystem	Format the disk.
	0025		
	0030		
	0031		
	0032		
	0374	System	1. Replace board in slot
			shown on screen.
			2. Replace system module.
		Power supply	1. Replace power supply.
		(expansion box)	2. Replace load resistor.
001002	Any	Basic video	Replace board in slot
	code	(in card cage)	shown on screen.
	0374	System	1. Replace board in slot
			shown on screen.
			2. Replace system module.

Table 1-3 Error Codes (Cont)

ID Number	Error Code	Problem Area	Corrective Action
001403	Any code	Extended bit map (in card cage)	<ol style="list-style-type: none"> 1. Check cable between basic video and extended bit map boards. 2. Replace board in slot shown on screen.
	0374	System	<ol style="list-style-type: none"> 1. Replace board in slot shown on screen. 2. Replace system module.
002004	0001 0002 0003 0210 0300 0310 0360 0370	RX subsystem	<ol style="list-style-type: none"> 1. Replace board in slot shown on screen. 2. Replace RX drive.
	0010 Any code	RX subsystem	<ol style="list-style-type: none"> 1. Insert initialized diskette. 2. Check RX drive cables. 3. Replace RX drive. 4. Replace board in slot shown on screen.
	0374	System	<ol style="list-style-type: none"> 1. Replace board in slot shown on screen. 2. Replace system module.
10050 or 20050 or 30050	0002 0002 0002 0007	PC380 base video failure	<ol style="list-style-type: none"> 1. Replace system module. 2. Replace EBO daughter module.
	0103 0106 0107	PC380 EBO plane 2 failure	<ol style="list-style-type: none"> 1. Replace EBO daughter module. 2. Replace system module.
	0203 0206 0207	PC380 EBO plane 3 failure	<ol style="list-style-type: none"> 1. Replace EBO daughter module. 2. Replace system module.

Table 1-3 Error Codes (Cont)

ID Number	Error Code	Problem Area	Corrective Action
177776	0375 or 0376	System	<ol style="list-style-type: none"> 1. Check data cables. 2. Replace board in slot shown on screen. 3. Replace RD disk drive. 4. Replace power supply. 5. Replace load resistor.
	0377	System	<ol style="list-style-type: none"> 1. Check data cables. 2. Replace board in slot shown on screen. 3. Replace RD disk drive. 4. Replace power supply. 5. Replace load resistor. 6. Replace system module.

NOTE 1

Error codes between 0001 and 0077 represent nonfatal errors and indicate that parts of TMS can still be used. Check error code problem area. If customer must wait for a replacement FRU, explain which functions are still usable. See note 2 for details.

NOTE 2

Serial data mode requires that modem analog loopback, 7910 modem analog loopback (in non-U.S. versions of product), and dial tone detect tests pass.

CODEC mode requires that CODEC loopback test passes. If voice unit is used to dictate and store voice, VU status request test must also pass.

DTMF mode requires that DTMF loopback test passes. This applies to dialing functions and data transfers using DTMF tones. *Attended voice mode*, at a minimum, requires that dial tone detect test passes. The telephone set (supplied by customer) always operates normally with no intervention from TMS. Even a complete failure of entire option does not disable use of telephone.

1.8 BOOT PROBLEMS

The Digital logo and floppy display indicates the system could not find a self-starting program on any system device. The system first looks at the diskette drive, then the hard disk, and then the options (in slot order) for a self-starting program.

To troubleshoot this problem, place a P/OS system diskette in a diskette drive. The system should erase the diskette image from the screen and boot the program. Use Table 1-4 if the problem remains.

1.8.1 Boot Failures

The Digital logo with numbers (none highlighted) and floppy display indicates that the system found a bootable device, tried to boot it, and failed partway through the boot process.

To troubleshoot this problem, place a self-starting diskette in the diskette drive. The system should erase the diskette image. Run the system unit test from maintenance services to determine the failure. If no failure is found, restart the system. If the error remains, replace the FRU/subsystem indicated by the first line of numbers to the right of the Digital logo. The two leftmost digits in the top line indicate the failing slot number. The last four digits in the top line indicate the failing unit number.

1.9 SYSTEM SOFTWARE ERROR

The system image with no highlights display means the system is functioning correctly, but it found an operating system error.

Note the eight six-character error codes on the screen and restart the system by turning the system power off and on. These characters are software status codes. Do not read them the way you read hardware error codes. If the problem continues, try a different software diskette. The diskette you have may be worn.

Sometimes a hardware failure produces a software code. For this error, the top number in the display is 000300 or 000400.

Table 1-5 lists software status codes and corrective action. These software status codes are for P/OS only.

1.10 KEYBOARD PROBLEMS

Table 1-6 lists possible keyboard problems and corrective action.

Table 1-4 Boot Problems

Symptom	Additional Checks	Corrective Action
An image of a diskette is on the screen under DIGITAL.	-	<p>Place self-starting software diskette in one diskette drive and restart system.</p> <p>If problem remains, check all RX cables and reseal RX I/O (controller) board.</p> <p>Replace I/O board.</p> <p>Replace RX drive.</p> <p>Replace system module.</p> <p>If problem goes away, check primary boot device (Paragraph 1.8).</p>
An image of a diskette is on the screen under DIGITAL, and there are six sets of numbers to the right of the diskette image.	If the system is connected in a network configuration, make sure that the DECNA identification number is logged at the host system.	<p>The first two digits to the left on the top line of numbers indicates the slot number that failed to boot. Remove the option indicated by this slot number, place self-starting software diskette in one diskette drive, and restart system.</p> <p>If problem goes away, replace module previously removed. If replacement module fails, refer to installation/owners manuals for option setup information.</p> <p>If problem remains, check all RX cables and reseal RX I/O (controller) board.</p> <p>Replace I/O board.</p> <p>Replace RX drive.</p>

Table 1-5 System Software Problems

Code	Problem Area	Corrective Action
Top Line Status Codes		
000100	P/OS keyboard handler	<ol style="list-style-type: none"> 1. Check cables and connections. 2. Replace keyboard. 3. Replace system module. 4. Reload operating system.
000200	Terminal driver (video subsystem and printer port)	<ol style="list-style-type: none"> 1. Check cables and connections. 2. Reseat option modules in card cage. 3. Reset all ICs in sockets on system module. 4. Replace system daughter boards, if present. 5. Replace system module. 6. Reload operating system.
000300	Executive/general	<p>If error occurred on first access of RX or RD subsystem, check that subsystem in following order.</p> <ol style="list-style-type: none"> 1. Check cables and reseat controller in card cage. 2. Replace drive. 3. Replace RX or RD subsystem controller. <p>If error was not on first access of mass storage, go to 000200 corrective action.</p>
000400	System start-up processing	Verifying write-protect tab is not on diskette. Go to 000300 corrective action.
100400	Terminal driver (video subsystem and printer port)	Go to 000200 corrective action.

Table 1-5 System Software Problems (Cont)

Code	Problem Area
Second Line Error Codes (For informational purposes only)	
000000	IOT in system state
000001	Stack overflow or cannot install task CBOOT
000002	Trace trap or breakpoint or cannot spawn task CBOOT
000003	Illegal instruction trap or cannot spawn task CMAIN
000004	Odd address or other trap to 4
000005	Segment fault
000006	A task on P/OS without a parent aborted
000007	EMT trap or required file not found
000010	TRAP trap

NOTE

These codes are for P/OS only.

Table 1-6 Keyboard Problems

Symptom	Additional Checks	Corrective Action
Keyboard does not work.	Check cables between keyboard and monitor, and monitor and system unit.	Replace keyboard.
Some keyboard keys do not work.	Check software program manuals. These keys may not work with this program.	This is not a problem.
	Run keyboard test on maintenance application diskette.	Replace keyboard. Replace system module.

1.11 PRINTER PROBLEMS

Table 1-7 helps isolate problems between the printer and the system. Use this table if the printer does not print.

1.12 COMMUNICATIONS PROBLEMS

Table 1-8 helps isolate problems between the communications device connected to the system and the system unit. Use this table if the system has trouble using the communications port.

1.13 DISKETTE PROBLEMS

Table 1-9 helps isolate diskette problems. Use this table if the system has trouble reading and writing on the diskette after the RX50 subsystem checks out.

1.14 HARD DISK PROBLEMS

Run the bigdisk block check test (Paragraph 1.4.10) to check for bad blocks on a hard disk. This test only works if P/OS is installed on the hard disk.

Table 1-7 Printer Problems

Symptom	Additional Checks	Corrective Action
Printer does not work when you try to print.	Check cable between printer and system unit.	Replace cable.
	Check printer controls.	Reset controls if needed.
	Run any printer diagnostic programs. Refer to printer's pocket service guide for more information.	If test fails, follow steps in printer's pocket service guide.
	Run system unit test in service mode on maintenance application diskette. Use loopback connector.	If test fails replace system module.

Table 1-8 Communications Problems

Symptom	Additional Checks	Corrective Action
Communications line is not working correctly.	Check cable between system unit and communications device.	Replace cable.
	Make sure communications feature settings match settings at other device.	Correct settings.
	Run system unit test in service mode on maintenance application diskette. Use loopback connector.	If test fails, replace system module.

Table 1-9 Diskette Problems

Symptom	Additional Checks	Corrective Action
System has trouble reading and writing diskettes.	Check diskette. Is it the correct one to use with your system?	Use a Digital diskette formatted for the Professional system.
	Diskette may be worn.	Try a new diskette.
	Run system unit test on maintenance application diskette.	If test fails, troubleshoot according to test results (Paragraph 1.4.3). If test runs correctly, check customer's media for wear, defects, and compatibility.

1.15 TESTS FOR OPTIONS

This section provides special information for servicing different options. Refer to Table 1-3 for error codes and corrective action. Remember to press **Help** for more information.

1.15.1 CP/M Option

To use this option, P/OS must be version 1.5 or later.

1.15.2 Real-Time Interface

For the power-up self-test, turn off or disconnect all equipment connected to the real-time interface's internal cable. Do not turn on other equipment until tests are complete.

CAUTION

For the real-time interface test (service mode), disconnect all equipment connected to the real-time interface's internal cable. Test signals may damage attached equipment.

P/OS must be version 1.7 or later. Errors with one port on the module do not usually affect other ports.

1.15.2.1 Customer Mode – For P/OS version 1.7 or later, you can select and run the real-time interface test like other tests in the system unit test (if installed with the update program). Refer to Paragraph 1.4.3 for information on how to run the test.

1.15.2.2 Service Mode – Press **F12, F19, F5** and follow the menu on the screen to select and run the the real-time interface test.

CAUTION

Disconnect all equipment attached to the internal cable connector on the rear panel. If you attach the loopback connector, select Loopback Connector Installed from the real-time interface test menu.

1.15.3 Telephone Management System

The telephone management system (TMS) needs P/OS version 1.7 or later and the maintenance application diskette. TMS has two diagnostic tests: the telephone management system test under the maintenance services menu (Paragraph 1.15.3.1) and the PRO/TMS communications test services (Paragraph 1.15.3.2)

1.15.3.1 Telephone Management System Test – If the diagnostic program has been installed, this test runs when you select the system unit test in customer mode. You can select the test by itself in service mode from the system unit test menu.

Test results are displayed like other test results in customer and service modes. Press **Help** for information and corrective action.

1.15.3.2 PRO/TMS Communications Test Services – This test has two parts: voice unit keypad test and remote data loopback tests. Run this test as an application as described in Paragraph 1.4.1.

The voice unit keypad test works only with the optional voice unit. This test verifies each key on the voice unit keypad. Follow the instructions on your screen. Press **Help** at any time.

If you have an external microphone with or without a foot switch, press the button to highlight the large part of the footswitch diagram.

Replace the voice unit and any of its accessories until the error indications are gone.

NOTE

Turn the power off before you remove or connect the voice unit, or you will reboot the computer.

The remote data loopback tests exercise TMS by transferring data between your system and the Digital Customer Services support system, or any other system with TMS installed.

Follow the instructions on your screen. Press **Help** for information. You will have to make a telephone call to the customer support system, where you will receive more information.

There are three kinds of tests in this group: data loopback, interactive, and long loopback.

The data loopback test is a continuity test for TMS and the telephone line.

The interactive test shows keyboard input on local and remote units. This test is useful for testing a system with one phone line.

If any errors are detected in either of these tests, rerun the tests two times. If errors continue, do the long loopback test.

The long loopback test is a long test for TMS and phone line integrity. This test displays bit error rate in service mode.

In service mode, if the bit error rate at the end of the test is less than or equal to 1.000 bit errors per 10^5 , then the telephone lines are valid. If the bit error rate is greater than 1.000 bit errors per 10^5 , perform the following procedure. (You must run this test four more times.)

1. Press **Print Screen** to get a copy of the screen display. Write the date and time on the printout.
2. Run the test again.
3. Continue until you have five printouts or copies of the screen display.
4. If at least two of the five tests show a bit error rate greater than 1.000 bit errors per 10^5 , then replace the TMS controller in the card cage and the telephone line interface (TLI) on back of the card cage (Paragraph 2.12).
5. Run the test five more times and get five more printouts.
6. If at least two of the five tests show a bit error rate greater than 1.000 bit errors per 10^5 , then there is a problem with the telephone line. Leave the printouts with the customer.
7. Tell the customer to call the telephone company to report the problem with the telephone line.

NOTE

The telephone company guarantees telephone lines that do not exceed 1.000 bit errors per 10^5 bits, 80 percent of the time. The printouts are evidence that this rate has not been met. Your customer can order a conditioned data line at additional cost from the telephone company.

1.15.4 DECNA Controller

The Digital Ethernet CTI Bus network adapter (DECNA) uses the PRO/DECNA maintenance services. The DECNA module works only with P/OS version 2.0 or later.

1. Remove the transceiver cable and connect the loop-back connector to the NET 1 connector on the rear panel.

CAUTION

Do not connect or disconnect cables while the test is running. You may damage the system module.

2. Select service mode from the maintenance services menu by pressing **F12**, **F19**, and **F5** in that order.
3. Select the system unit test. Press **Do**.
4. Select DECNA. Press **Do**.
5. Select a single pass test. Press **Do**.
6. Wait for the test results.

Press **Help** for information on errors and corrective action. If the test passes, reconnect the transceiver cable and perform the procedure for additional network devices, in sequence (Figure 1-3).

NOTE

If the DECNA controller fails the power-up self-test, leave the computer turned on for at least two minutes. Then turn the power off and on. If it does not fail the second time, disregard the first failure. If it fails the power-up self-test again, replace the DECNA controller and retest.

Refer to Chapter 4 for information about testing the Digital Ethernet local network interconnect (DELNI) with PRO/DECNA maintenance services.

1.16 THE ANALOG DATA MODULE (ADM)

The analog data module (ADM) is an optional data collection device, which is attached to the real-time interface (RTI) module (Figure 1-4). The ADM features an 8-channel multiplexer, a 16-bit analog-to-digital converter, and a 16-bit digital input/output barrier strip.

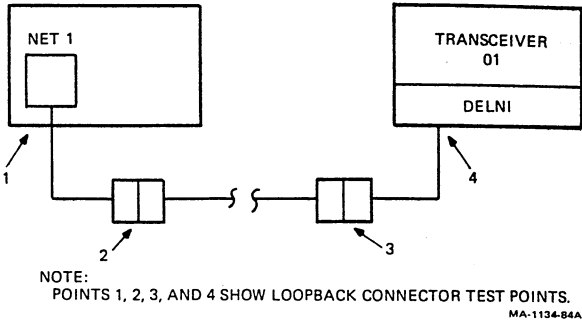
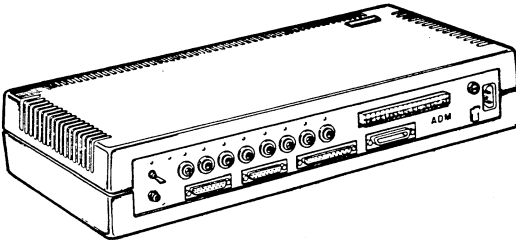

Figure 1-3 DECNA Loopback Connector Test Points



MR-12835
MA-1404-84

Figure 1-4 Analog Data Module (ADM)

1.16.1 ADM Troubleshooting – System Unit Test

Before you determine that a problem exists in the ADM, run the Maintenance Services System Unit Test. It is assumed that you have already performed the maintenance services update to include the RTI diagnostics. The ADM should be left on and connected if the loopback is not installed during the system unit test.

If the system unit test does not report any errors, run the ADM diagnostics to isolate the faulty ADM FRU, if any.

1.16.2 FRU Isolation

The ADM has the following four FRUs.

- Power supply
- LED board
- Motherboard
- Digital I/O board

Figure 1-5 shows where these FRUs are located in the ADM.

You can isolate faults to the FRUs with the help of the ADM diagnostics and ADM test box (70-22016-01). The test box derives its power from the +5-volt jack on the ADM. The test box comes with a power cord, eight analog connector cables, and a 20-conductor digital barrier strip cable.

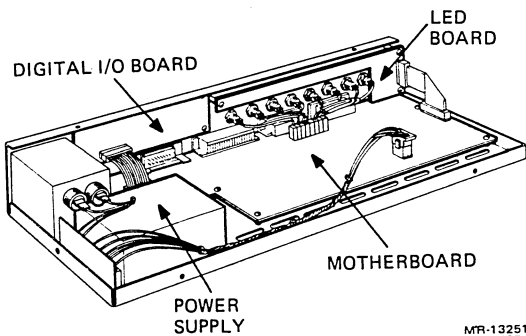

MR-13251
MA-1407-84

Figure 1-5 ADM FRUs

1.16.3 Troubleshooting

Check the power supply first by viewing the LEDs on the motherboard. You can see these LEDs by looking down into the ADM chassis from the back. Both the red and green LEDs should be on. If either LED is off, replace the power supply.

If both LEDs are on, connect the test box and run the ADM diagnostics as described in the following paragraph.

1.16.3.1 Connecting the Test Box - Connect the test box as follows.

1. Turn off power to the ADM. Place the ADM test box in front of the ADM. Connect the power cable for the test box to the +5-volt jack on the ADM panel. Connect the analog cables from the test box to the ADM analog channels in a one-to-one correspondence. That is, connect channel 0 on the ADM to output 0 on the test box. When correctly connected, no analog cable should cross any other analog cable.
2. Connect the digital cable from the test box to the digital I/O barrier strip. Use a small screwdriver or ball-point pen to press in the red slot on the barrier strip, then insert the wire in the hole. Release the red tab to hold the wire. There are 20 connections to make. Table 1-10 lists these connections.
3. Turn on power to the ADM. Check if the reference LED on the test box is on. This LED is just above the power input jack. If it is not on, and the ADM power supply is good, the test box is not receiving +5-volt power. The most likely cause is that the fuse on the LED board is blown. In that case, you should swap the entire LED board. If that does not correct the problem, the +5-volt power cord or the test box itself may be bad.

The reference LED, when on, indicates that the test box reference voltages, used to produce output voltages, are within the required tolerance.

Table 1-10 Digital Cable Connections

ADMPC Connector* Number	Front Panel Label	Color	Signal
1	D IN GND	White	GROUND
2	D IN GND	Tan	GROUND
3	D IN 0	Black	D IN TEST 0 H
4	D IN 1	Brown	D IN TEST 1 H
5	D IN 2	Red	D IN TEST 2 H
6	D IN 3	Orange	D IN TEST 3 H
7	D IN 4	Yellow	D IN TEST 4 H
8	D IN 5	Lt. Green	D IN TEST 5 H
9	D IN 6	Lt. Blue	D IN TEST 6 H
10	D IN 7	Violet	D IN TEST 7 H
11	D OUT 0	Black/ White	D OUT TEST 0 H
12	D OUT 1	Brown/ White	D OUT TEST 1 H
13	D OUT 2	Red/Black	D OUT TEST 2 H
14	D OUT 3	Orange/ Black	D OUT TEST 3 H
15	D OUT 4	Yellow/ Black	D OUT TEST 4 H
16	D OUT 5	Green/ Black	D OUT TEST 5 H
17	D OUT 6	Blue/ Black	D OUT TEST 6 H
18	D OUT 7	Violet/ Black	D OUT TEST 7 H
19	D OUT GND	Lt. Grey	GROUND
20	D OUT GND	Pink	GROUND

* Left to right on front panel connector

1.16.3.2 Running the ADM Diagnostic with Test Box –
Run the ADM diagnostic as follows, with the test box connected.

1. Make sure the test box reference LED is on, and the test box is connected.
2. The ADM should be on and you should have previously run the system unit test to check the RTI module.
3. Turn off power to the Professional.
4. Insert the P/OS system diskette in the disk drive.
5. Turn on power to the Professional.

The Digital logo appears and the diagnostic prompts you to load an application.

6. Insert the ADM diagnostic diskette and press **Resume**.

The diagnostic begins by prompting you for information.

7. When the diagnostic asks you if you want to run conversions on multiplexer channel 0, type **NO**.
8. When the diagnostic prompts you to select analog tests 22 through 29, enter **ALL**. When you select **ALL**, the diagnostic takes one hour and five minutes to run. Test 29 (differential linearity) takes one hour to run.
9. The diagnostic then prompts you to press **Return** when ready. Before you press **Return**, type **FSE**.
10. The diagnostic then asks if the test box is connected. Type **YES**.
11. The ADM diagnostic begins running. There are 29 subtests within the diagnostic. A subtest has run successfully when the message that the next subtest has begun appears. Tests 1 through 21 take about five minutes to run. Tests 22 through 29 are the analog tests. Tests 22 through 28 take one minute each to run. Test 29 takes one hour (maximum) to run. If a test fails, an error message appears and the diagnostic continues.

12. Run test 19 to check the LED board. The leftmost LED, is the red reset LED. The next LED is the green sweep LED (indicated by >>>). The next eight LEDs are the green analog channel LEDs.

Test 19 turns on the analog channel LEDs in sequence (channels 0 through 7). If any LED does not come on, replace the LED board. The sweep LED is on during tests 16 and 17. If the sweep LED does not come on, replace the LED board.

13. If no errors are reported, and the LED board was okay (step 12) the ADM is working correctly. You do not have to replace any FRUs.
14. If an error is reported, note the test number that failed. If any test number other than 1 or 17 fails, replace the motherboard.
15. If test 1 or 17 fails, you must rerun the diagnostic without the test box (refer to Paragraph 1.16.3.3). It is not necessary to disconnect the test box, just answer NO when the diagnostic asks you if the test box is connected. Enter NONE when the diagnostic prompts you for ALL, NONE, or SUBSET.
16. If test 1 or 17 does not fail with the test box disconnected, the digital I/O board caused the fault the first time. You should replace the digital I/O board. If test 1 or 17 fail again, you should replace the motherboard.

1.16.3.3 Running the ADM Diagnostic without Test Box – If the test box is not available, you can still troubleshoot the ADM. Run the diagnostics as described above, but do not type FSE before you press **Return** to start the diagnostic. The question “Is the test box connected?” does not appear. Tests 19, 20, and 21 do not run. Select ALL when the diagnostic asks you to choose the analog tests. If any test fails, replace the motherboard. Without the test box, you cannot isolate faults to the LED board or the digital I/O board.

1.16.3.4 Power Supply Fault Isolation Summary – You can isolate faults to the power supply by checking its LED indicators. Do this by looking down into the ADM chassis through the ventilation slots. The power supply is in the right rear corner of the ADM (when you are facing the ADM panel). Two LEDs are visible on the motherboard. One LED is green, the other is red. Both the green and red LEDs should be on while power is supplied to the ADM. If either LED is off, replace the power supply.

1.16.3.5 LED Board Fault Isolation Summary – When diagnostic test 19 executes, the LEDs come on in sequence from channel 0 through 7. Tests 16 and 17 turn on the sweep LED. You can test the RESET LED by pressing the RESET switch. (Do not do this while the diagnostic is running.) If one of the LEDs does not come on, you should replace the LED board.

The LED board also contains a fusible resistor, which protects the +5-volt jack. If the reference LED on the test box does not come on when you insert the power cord, and the ADM is on and the power supply is good, you should replace the LED board. The power reference LED on the test box is just above the power input jack.

1.16.3.6 Mother Board Fault Isolation Summary – If any ADM diagnostic test except test 1 or 17 fails, replace the motherboard. If test 1 or 17 report an error, run the diagnostic as described in Paragraph 1.16.3.2. If the failure reoccurs, replace the motherboard. If the failure does not reoccur, replace the digital I/O board.

1.16.3.7 Digital I/O Board Fault Isolation Summary – The digital I/O board is faulty if test 1 or 17 fails with the test box connected, but does not fail when the test box is disconnected.

1.17 SERIAL LINE UNIT OPTION

The PC3XC-BA quad serial line unit (SLU) provides the Professional system with four additional serial ports to connect peripheral devices. The SLU option consists of an interconnect box, option module (in the system unit), and option cable (Figure 1-6). One or two SLUs may be used on the Professional. The interconnect box (or boxes) can be attached to the back of the system unit using two Velcro pads on each box.

The following paragraphs describe configuring and troubleshooting the SLU.

1.17.1 SLU Configuration

The four I/O ports on the SLU interconnect box provide a modem control selection capability as follows (Figure 1-7).

1. In configuration 2/2, two ports (1 and 3) have full asynchronous modem support, while the other two ports (0 and 2) have serial data line capabilities only.
2. In configuration 4/0, all four channels provide partial modem control with a limited number of input/output control signals.
3. To change the modem control configuration, plug the option cable into the corresponding side connector in the interconnect box. (See Figure 1-7.)

NOTES

1. Because the option cable is short, and to make the modem control selection easier and safer, the side connector on the interconnect box should face the left. Everytime you change SLU configuration, turn the box 180 degrees to have the required connector on the left side of the box (Figure 1-7).
2. Notice the orientation of the 25-pin port connectors on the interconnect box in relation to the SLU configuration selection (Figure 1-7).

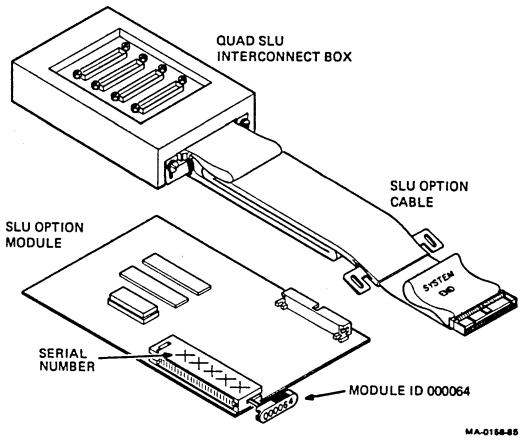

Figure 1-6 SLU Option Kit

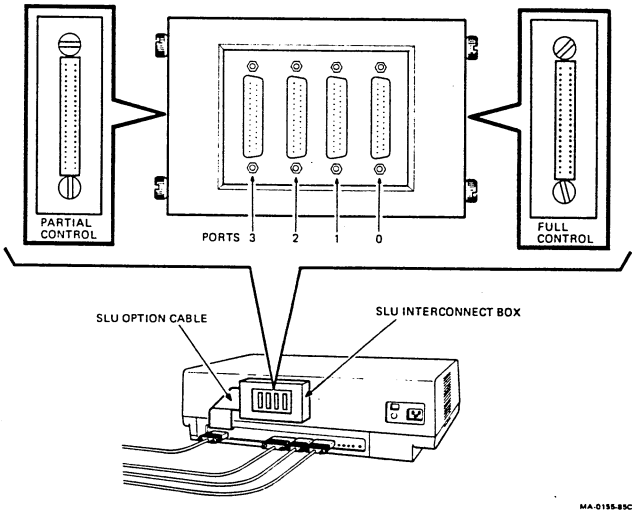

Figure 1-7 SLU Configuration and Cabling

1.17.2 Power-Up Self-Test

The power-up self-test runs each time you turn on the system. It checks the functionality of the SLU option module only. For self-test indications and error codes, see Paragraphs 1.3 and 1.7 and Tables 1-1, 1-2, and 1-3.

NOTE

The SLU module ID number is 000064.

1.17.3 SLU Service Diagnostic

This diagnostic tests the SLU module (like the self-test) and also provides a way to loop back signals to check the option cable and the connectors on the interconnect box.

To use the service diagnostic, you must update the Professional maintenance services using the PRO/Quad Maintenance Services diskette supplied with the option.

NOTES

Maintenance services version 3.0 and later can test multiple options with the same ID number. If two SLUs are installed on a Professional, both can be tested.

Earlier versions of maintenance services can only test one option per ID code. So, the option in the lowest numbered slot is tested. The others are ignored.

You must remove the frontmost SLU option module from the card cage in order to test a second SLU module.

To update maintenance services, proceed as follows.

1. Load maintenance services, choose "Update maintenance services" from the menu, and follow the instructions.
2. Insert the PRO/Quad Maintenance Services diskette in drive 2 when asked to do so.
3. After the update is completed, enter the service mode (press the **F12**, **F19**, and **F5** keys) and check for quad SLU on the system unit test listing.

To completely test the SLU option, install a loopback connector (PN 29-24795-00) in each of the four SLU ports. Then select "Loopback connector installed" and "4-line SLU" from the system unit test selection menu.

NOTE

If the loopback connectors are not installed, select only "4-line SLU." The resulting test still determines whether errors originated in the option module or the interconnect box. However, it does not check the external I/O connectors (ports).

If faults occur during the system unit test, they are shown in the summary at the end of the test. One or more faulty ports may be called out. Ports that pass the test can still be used.

If the error cannot be localized to a port, the option module is at fault.

To check the probable error causes, press the **Help** key for on-line assistance and see Table 1-3.

CAUTION

If the SLU diagnostic does not identify the faulty FRU by error codes, swap the components in the following order.

1. SLU option module
2. SLU interconnect box
3. SLU option cable

1.18 HARD DISK EXPANDER BOX OPTION

This option allows an additional RD5X hard disk drive in a Professional 380 system. The option consists of an expander box, a 120 V or 220 V power supply, a +5 V load resistor, and data cables.

NOTE

A second disk controller module must be installed in the system unit.

The expander box option is tested as the second RD5X disk drive in the system, and both RD subsystems are identified by slot numbers with the lowest number listed first.

The power supply and +5 V load resistor are two possible failure causes in the RD subsystem. The +5 V load resistor applies a continuous minimum load to the power supply for its proper operation. The failing load resistor can cause intermittent disk and power-up self-test errors.

The following paragraphs describe how you can troubleshoot the expander box option.

1.18.1 Power-Up Self-Test

The power-up self-test runs at every system power-up. It checks the functionality of the option controller module only. For power-up indications, see Paragraph 1.3 and Tables 1-1 and 1-2. System faults and corrective actions are described below. Errors found during the self-test are isolated to the FRU.

Both RD subsystems have the ID number 000401.

If the highlighted module has this ID code, check the slot number to identify the faulty RD subsystem. Error codes 0013, 0025, 0030, 0031, and 0032 indicate that the RD disk is not formatted correctly.

1.18.2 Service Diagnostic

This is the same diagnostic you run when testing the built-in RD drive. Enter service mode through the maintenance services menu. (Press the **F12**, **F19**, and **F5** keys.) If the Professional has two RD subsystems – one in the system unit, the other in the expander box – they will both be listed as “Hard disk subsystem.” However, the RD subsystem with the lowest slot number will be listed and tested first.

NOTES

Maintenance services version 3.0 and later lists and tests multiple RD options with the same ID code.

Maintenance services version 2.0 or earlier can only test one option per ID code. So, the option (module) in the lowest numbered slot is tested. The others are ignored.

You have to remove the frontmost RD controller module from the card cage in order to test a second RD subsystem.

Service mode lets you run all or part of the system unit test. In service mode, the screen display lists the following tests and programs.

```
System unit test
Keyboard test
Printer test
Configuration display program
Bar pattern program
Video alignment pattern program
Update maintenance services
Bigdisk block check
Minidisk block check
RX speed test
Hard disk formatter
```

You can test any combination of RD subsystems. In the system unit test, if you choose "All devices," both RD drives are tested with the rest of the system. The system unit test summary screen lists the RD drives in the same order as the selection menu.

If you press the **Help** key, the errors are listed in the same order as in this summary screen.

The Professional system has two service mode features that help in testing the RD drives. The expander box option uses them as follows.

Hard Disk Formatter – This feature quickly formats a new hard disk so the system unit test can be run on this disk. You can choose it from version 3.0 of the service mode test menu.

The hard disk formatter only formats one RD disk at a time. Thus, you can only select one RD subsystem from the submenu.

NOTE

Hard disk formatting is only a service feature that allows you to run the system unit test. It does NOT fully format an RD disk. You still must use the standard formatting program before using the disk with applications. The hard disk formatter is only part of maintenance services version 3.0.

Bigdisk Block Check – This feature determines if there are new bad blocks on the hard disk. It is described in Paragraph 1.4.10.

NOTE

If there are two RD subsystems, you will be asked to specify which RD drive you want to be checked. You select the hard disk subsystem to be tested from the submenu displayed after you select “Bigdisk block check.”

Table 1-3 lists the expander box option error codes and corrective actions.

2 REMOVAL AND REPLACEMENT

2.1 GENERAL

This chapter tells you how to remove and replace the field replaceable units (FRUs) in the Professional system. Paragraph 2.17 provides the Recommended Spares List (RSL). Appendix B contains exploded views of the FRUs. The exploded view drawings provide location, part name, and part number of each FRU.

CAUTION

Use a static protection kit (PN 29-11762-00) when handling any internal components.

2.2 REMOVAL AND REPLACEMENT PROCEDURES

Figure 2-1 shows all FRU removal procedures and the sequence you must follow. For example, to remove any I/O board from the system, you must remove the top cover first. To replace an FRU, perform the removal steps in reverse.

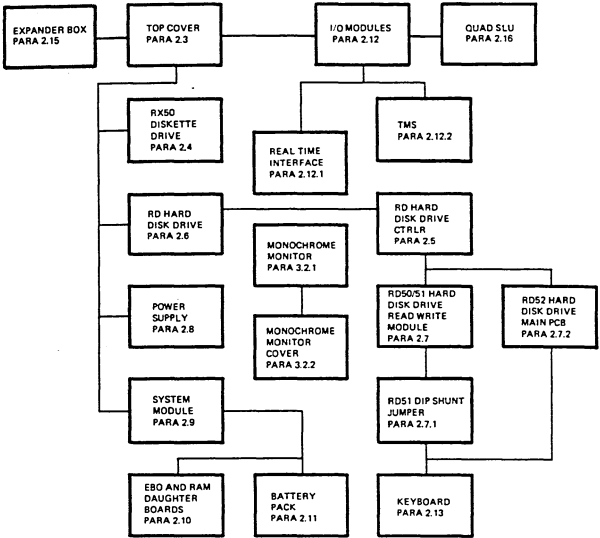

MA-1132-048

Figure 2-1 FRU Removal Sequence

2.3 TOP COVER

Remove the top cover as follows.

1. Turn the system unit power switch off and remove the ac power cord from the wall outlet and the power receptacle on back of the system unit (Figure 2-2).
2. If the circuit breaker tripped, reset the circuit breaker by pushing it in (Figure 2-3).
3. Close the diskette drive door(s) (Figure 2-4).

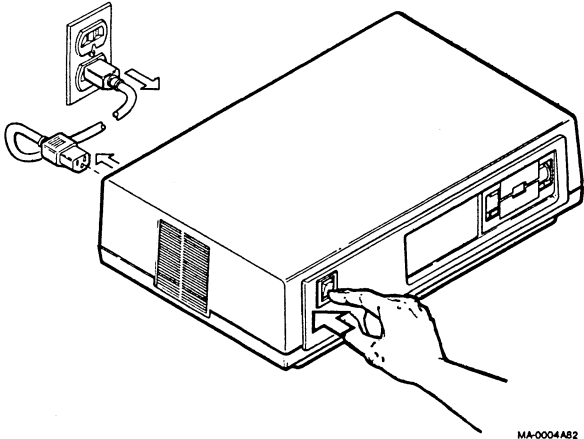

MA-0004A82

Figure 2-2 Power Switch and AC Power Cord

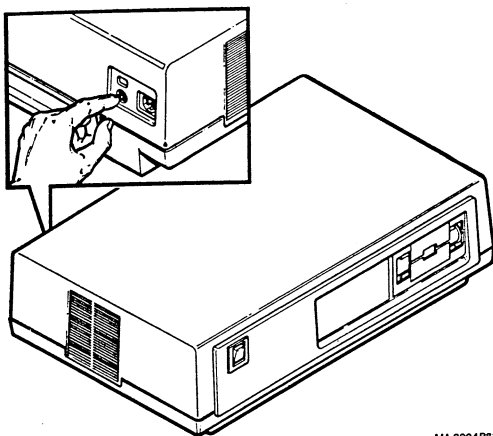

MA-0004B82

Figure 2-3 Circuit Breaker

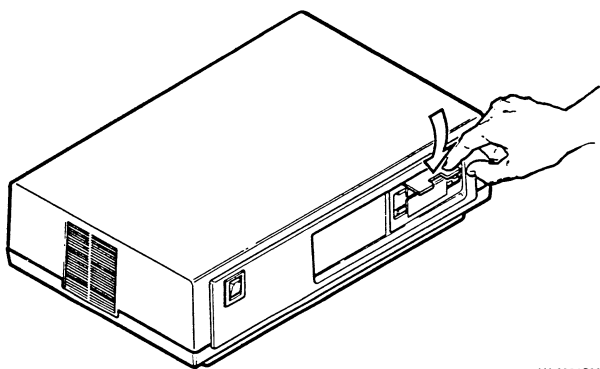

MA-0004C82

Figure 2-4 Diskette Drive Door(s)

62 REMOVAL AND REPLACEMENT

4. Find the two top cover releases and pull each release to the front of the unit (Figure 2-5). The release should move about 1/2 inch. To hold the release open, move the pin into the locked position.
5. Grasp the top cover on each side and lift the cover straight up (Figure 2-6).

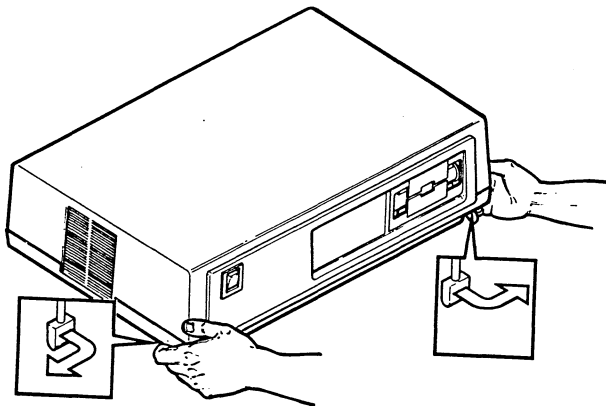

MA-0004D82

Figure 2-5 Top Cover Releases

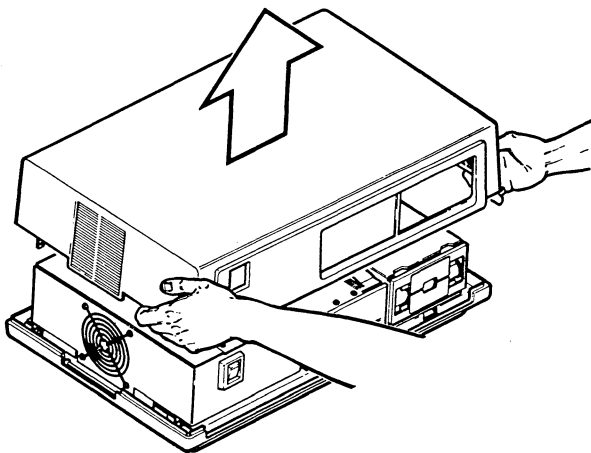

MA-0004E82

Figure 2-6 Removing Top Cover

2.4 RX50 DISKETTE DRIVE

Remove the RX50 diskette drive as follows. You need a pen or similar object.

1. Remove top cover (Paragraph 2.3).
2. Disconnect the I/O cable and dc power cable from the diskette drive. You can disconnect the I/O cable by pulling straight up on the white cable pull (Figure 2-7).

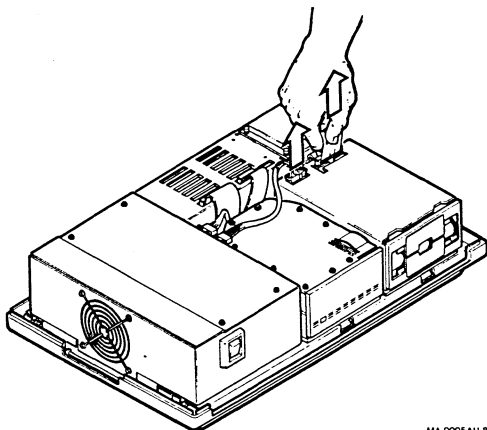

MA-0005AU-82

Figure 2-7 I/O Cable and DC Power Cable

3. Find the release tab at the front center of the diskette drive. Use a pen or similar object to push down on the release tab, then slide the diskette drive assembly to the front of the system unit (Figure 2-8).
4. Remove the diskette drive (Figure 2-9).

NOTE

The diskette drive is a single FRU. Do not disassemble the diskette drive or remove any printed circuit boards. You must make all adjustments in a special test configuration.

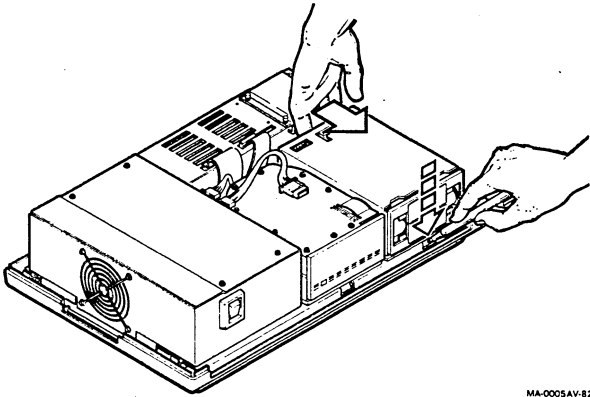

MA-0005AV-82

Figure 2-8 Diskette Drive Release Tab

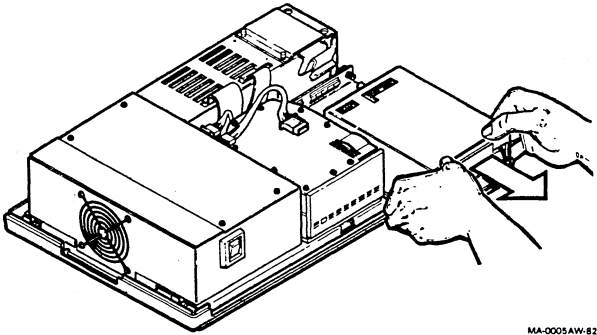

MA-0005AW-82

Figure 2-9 Removing Diskette Drive

2.5 RD HARD DISK CONTROLLER

There are two versions of the RD controller. One version is for the RD50 and RD51. The other version is for the RD52.

The RCD50 controller (PN 54-15134-00) is for the RD50 and RD51. Do not use a controller with any other part number for an RD50 or RD51. The RCD50 will not work with RD52 drives.

The RCD52 controller (PN 54-15134-01) is for the RD52. Use this controller with RD52s only.

The part number is printed on one side of the printed circuit board. If the number is 54-15134 (the 00 extension is assumed) this controller is for the RD50 and RD51. If the part number has a 01 extension, this controller is for the RD52.

2.6 RD HARD DISK DRIVE

Remove the RD hard disk drive as follows. You need a pen or similar object.

1. Remove the top cover (Paragraph 2.3).
2. Disconnect the two I/O cables from the I/O board. You can disconnect each cable by pulling straight up on the white cable pull (Figure 2-10).
3. Find the release tab below the front of the hard disk drive. Use a pen or similar object to push down on the release tab, then slide the hard disk drive assembly about 2 inches to the front of the system unit (Figure 2-11).
4. Disconnect the 4-wire dc power cable from the rear of the hard disk drive (Figure 2-12).

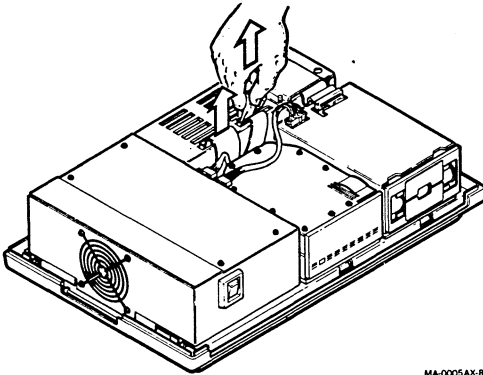

MA-0005AX-82

Figure 2-10 Disconnecting I/O Cables from I/O Board

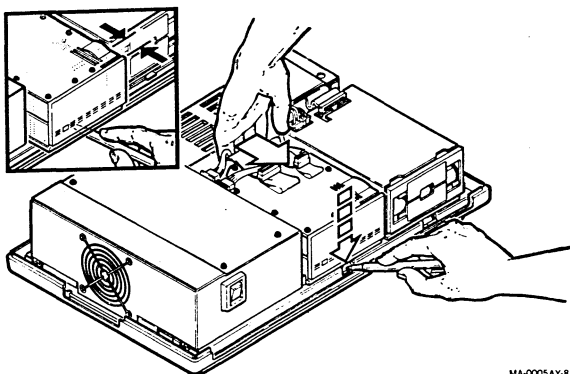

MA-0005AY-82

Figure 2-11 Hard Disk Drive Release Tab

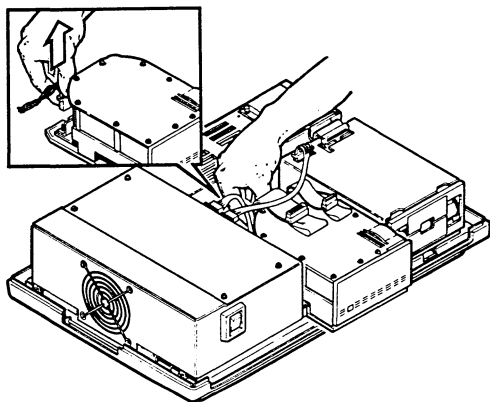

MA-0005AZ-82

Figure 2-12 4-Wire DC Power Cable

5. Remove the hard disk drive by sliding it out of the system unit (Figure 2-13).

NOTE

Replace the RD hard disk drive with the same kind of hard disk drive (RD50, 5 megabytes, or RD51, 10 megabytes).

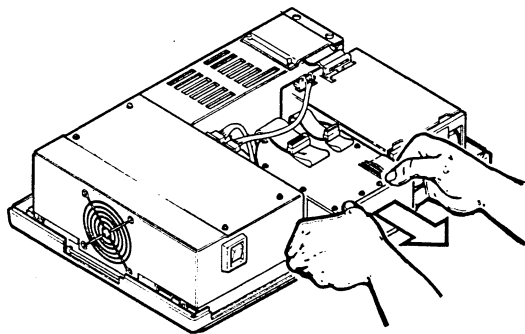

MA-0005BA-02

Figure 2-13 Removing Hard Disk

2.7 RD50/51 HARD DISK DRIVE READ/WRITE BOARD

Remove the RD50/51 hard disk drive read/write board as follows. You need a small phillips screwdriver and a small blade screwdriver.

NOTE

See Paragraph 2.7.2 for the RD52 PC board.

1. Remove the top cover (Paragraph 2.3).
2. Remove the hard disk drive (Paragraph 2.6).
3. Use a small phillips screwdriver to remove the four screws that hold the drive skid plate to the drive (Figure 2-14). Remove the drive skid plate.
4. Use a small blade screwdriver to remove the four screws that hold the read/write board to the disk drive (Figure 2-15).

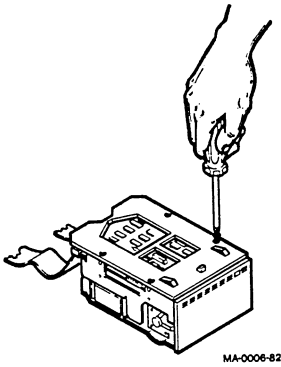

MA-0006-82

Figure 2-14 Drive Skid Plate

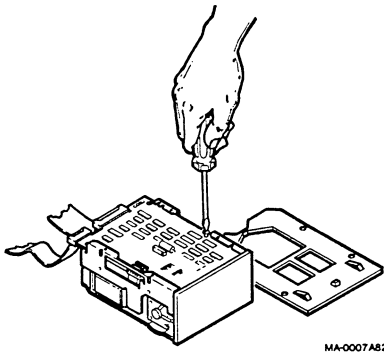

MA-0007A82

Figure 2-15 Read/Write Board

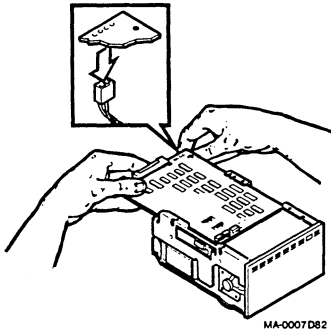

Figure 2-18 P4 Connector

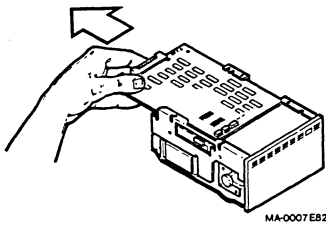

Figure 2-19 Removing Read/Write Board

2.7.1 DIP Shunt Replacement (RD50/51 Hard Disk Drive)

The read/write board on the RD50 and RD51 hard disk drive has a dual in-line package (DIP) shunt. Make sure the shunt is in place and looks like the one in Figure 2-20.

You can exchange the shunt from one RD51 read/write board to another (Paragraph 2.6). Use a small blade screwdriver to lift the shunt.

CAUTION

Be sure the 14-pin jumper shunt is positioned as shown in the 16-pin socket.

WARNING

Be careful. The shunt pins are sharp.

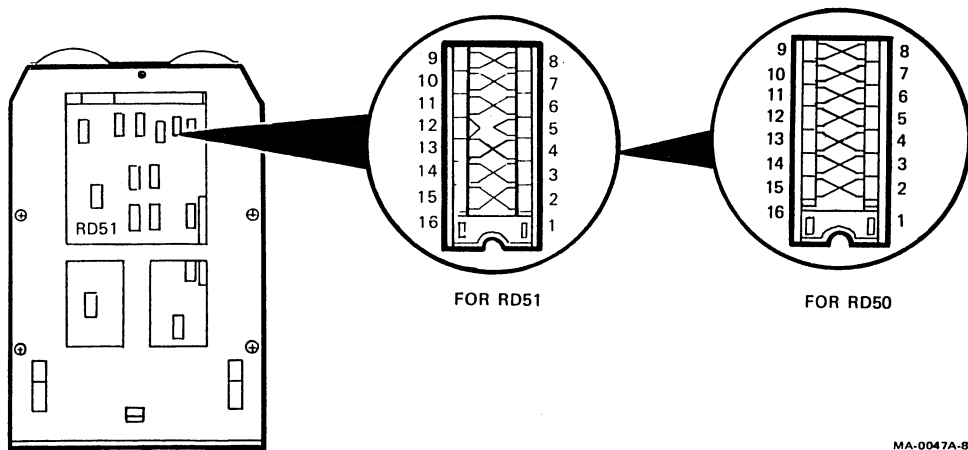

Figure 2-20 DIP Shunt Locations

2.7.2 RD52 Board

Remove the RD52 hard disk drive PC board as follows. You need a phillips screwdriver.

NOTE

The screws that you will remove are different lengths. You must reinstall them in the same place.

1. Remove the top cover (Paragraph 2.3).
2. Remove the hard disk drive (Paragraph 2.6).
3. Use a phillips screwdriver to remove the four screws that hold the drive skid plate to the drive (Figure 2-14). Then, remove the drive skid plate.
4. Remove the two phillips screws that hold the front bezel to the drive (Figure 2-21).
5. With your fingers, unplug the two-pin connector near the bezel on the main PC board (Figure 2-21).
6. Remove the bezel by carefully pulling away from the drive. (The bezel is held in place with Velcro.)
7. Remove the remaining three phillips screws that hold the PC board in place (Figure 2-21).
8. Lift the main PC board straight up until it is clear of the chassis. This disconnects P4, the fixed plug at the bezel end of the drive base casting (Figure 2-21).
9. Disconnect the 10-pin connector on the heat sink side of the main PC board (Figure 2-21).

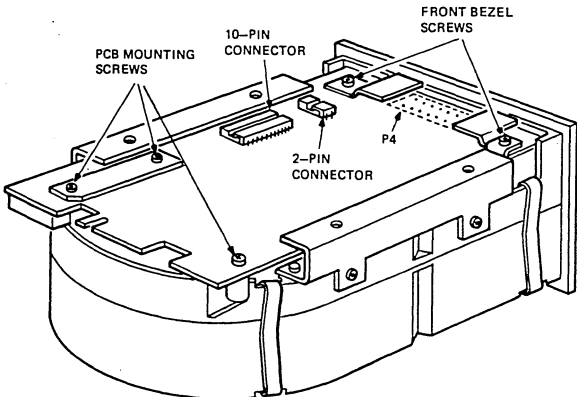

MA-1381-84

Figure 2-21 Removing RD52 PCB

10. Install the new PC board by doing steps 1 through 10 in reverse. Make sure that you line up connector P4 when installing the PC board. Put screws back in the same places (there are four lengths). Check, and if necessary, set the drive address jumpers before you reinstall the drive. In the PC300 family, you should install address jumper DS1 and remove address jumpers DS2, DS3, and DS4 (Figure 2-22).

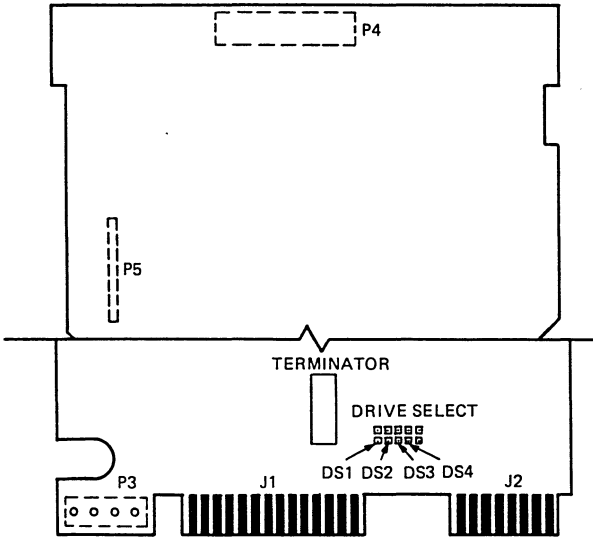

MA-1382-84

Figure 2-22 RD52 Jumper Options

2.7.3 RD31 Device Electronics Board

Remove the RD31 hard disk drive device electronics board as follows. You need a small phillips screwdriver and a small-blade screwdriver.

CAUTION

Do not remove any of the screws that secure the top cover (cover/filter assembly) to the base casting. Removing any of the screws violates the clean area.

1. Remove the top cover (Paragraph 2.3).
2. Remove the hard disk drive (Paragraph 2.6).
3. Use a phillips screwdriver to remove the four screws that hold the drive skid plate with an attached ground clip to the base casting (Figure 2-23). Then remove the drive skid plate.

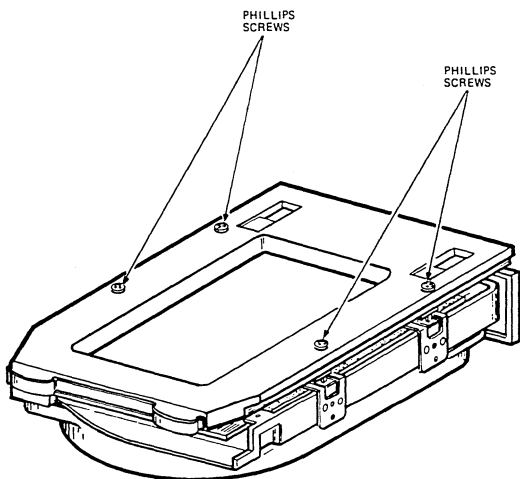

SHR 0438 85
MA-0008-86

Figure 2-23 Drive Skid Plate

4. Use a small-blade screwdriver to remove the three screws that hold the device electronics board to the disk drive (Figure 2-24).

CAUTION

When replacing the device, make sure you replace the insulating washer at the front of the unit.

5. Disconnect the J4, J5, and J6 connectors from the device electronics board (Figure 2-25).

NOTE

The cables connected to J4, J5, and J6 are fragile. Do not bend sharply or pull on these cables.

6. Install the new device electronics board by doing steps 1 through 5 in reverse.

NOTE

When installing connector 5 to jack 5, notice that jack 5 has nine pairs of pins, while connector 5 has eight pairs of slots. This connector does not have a key and could be replaced incorrectly. Do not use the pin closest to the LED (Figure 2-26).

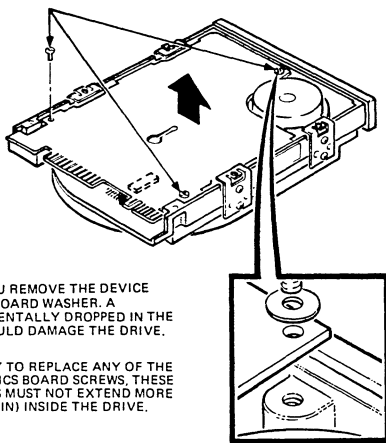

CAUTION: MAKE SURE YOU REMOVE THE DEVICE ELECTRONICS BOARD WASHER. A WASHER ACCIDENTALLY DROPPED IN THE DISK DRIVE COULD DAMAGE THE DRIVE.

NOTE: IF IT IS NECESSARY TO REPLACE ANY OF THE DEVICE ELECTRONICS BOARD SCREWS, THESE MOUNTING SCREWS MUST NOT EXTEND MORE THAN 0.64 CM (0.25 IN) INSIDE THE DRIVE.

LJ 0694
SHR-0439-B5
MA-0011-86

Figure 2-24 Device Electronics Board

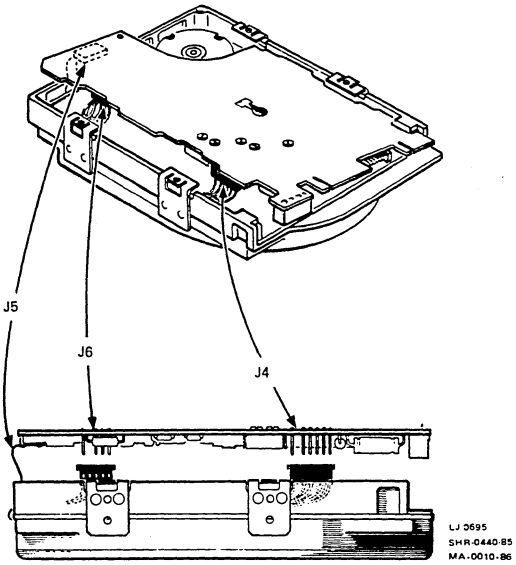

Figure 2-25 J4, J5, and J6 Connectors

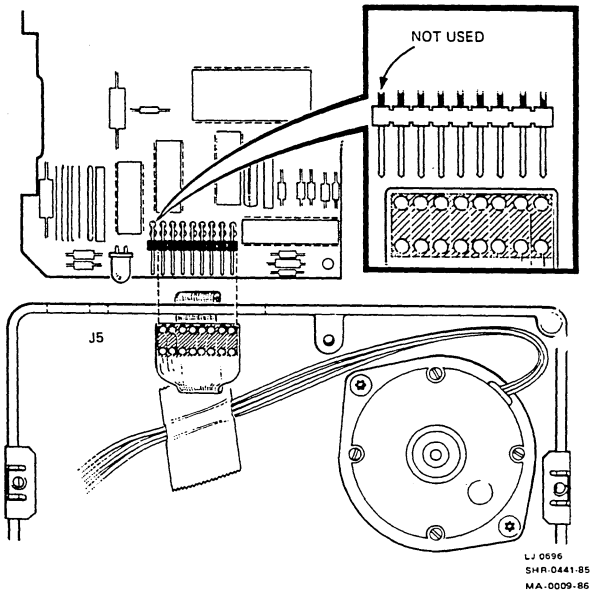
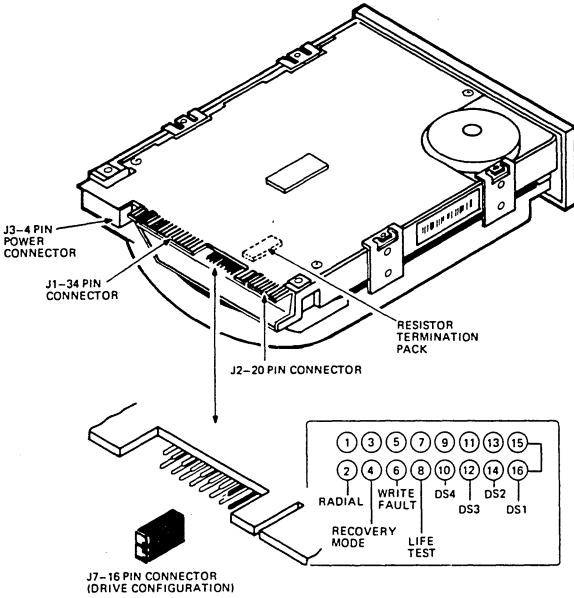

Figure 2-26 Installing Connector 5

7. Check the drive address jumpers and if necessary set them before you reinstall the drive. You should install a jumper across pins 15 and 16 of the device electronics board (Figure 2-27).

NOTE

The RD31 should be set to Drive Select 1 (DS1) for all Professional Series installations.



SHR 0418-85
MA 0007-86

Figure 2-27 Device Electronics Board Configuration Components

2.8 POWER SUPPLY

Remove the power supply as follows.

1. Remove the top cover (Paragraph 2.3).
2. Disconnect the 16-pin system module power connector from the rear of the power supply. You can disconnect the cable by pulling straight back on the white cable pull (Figure 2-28).
3. Disconnect the 4-pin mass storage device power connectors from the side of the power supply (Figure 2-29).

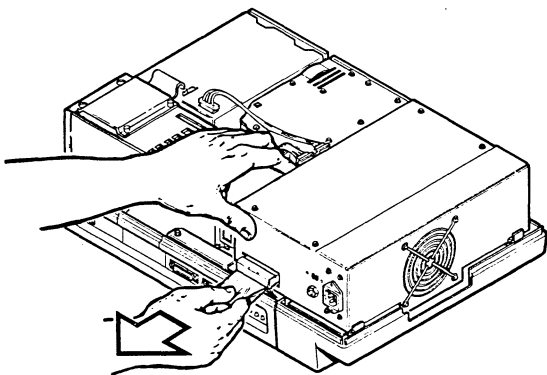

MA-0008P-85

Figure 2-28 16-Pin System Module Power Connector

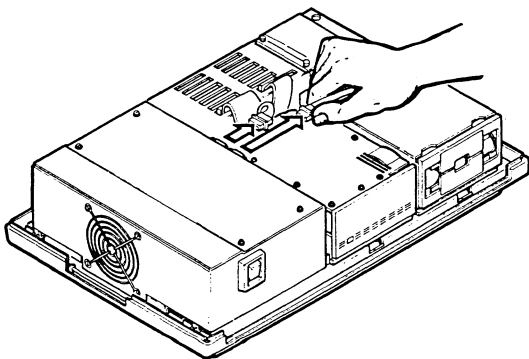

MA-0005BC-82

Figure 2-29 4-Pin Mass Storage Device Power Connector

4. Find the two release clips on the side of the power supply near the fan assembly. Pull each clip out (Figure 2-30).
5. Lift the power supply assembly out of the system unit (Figure 2-31).

NOTE

The power supply is an FRU. You can replace the fan if it becomes noisy (PN 12-13185-03). The power supply is not adjustable and does not contain replaceable circuit boards.

When you replace the power supply on the system chassis, push down in the center to latch it in place.

2.9 SYSTEM MODULE

Remove the system module as follows. You need a pen or similar object.

1. Remove the top cover (Paragraph 2.3).
2. Disconnect any cables connected to the rear of the system module (Figure 2-32).

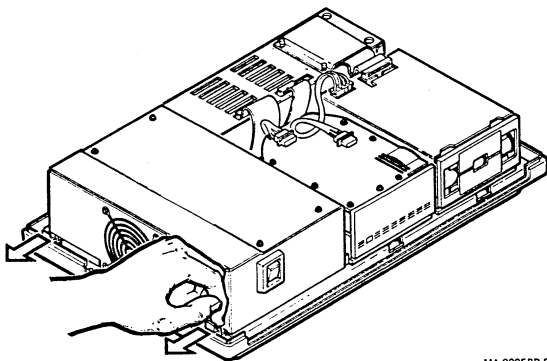

MA-0005BD-82

Figure 2-30 Power Supply Release Clips

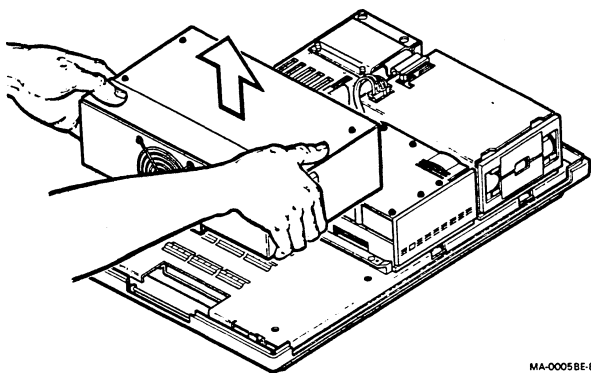

MA-0005BE-B2

Figure 2-31 Removing Power Supply Assembly

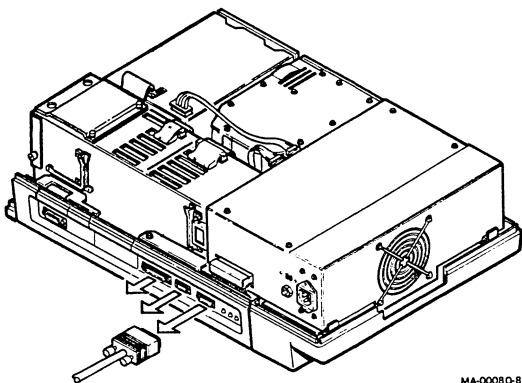

MA-0008Q-B2

Figure 2-32 System Module (Rear)

3. *Perform this step only if you are replacing the system module.* Remove all I/O option boards from the card cage (Paragraph 2.12).

NOTE

Disconnect any cables attached to option boards from the top of the card cage. Also remove the telephone line interface (TLI) board from the rear of the system module if the telephone management system (TMS) is installed (Figure 2-33).

4. Disconnect the diskette drive I/O cable from the diskette drive and the hard disk I/O cables from the hard disk drive I/O board (Figure 2-34).
5. Find the release tab at the front center of each disk drive. Use a pen or similar object to push down the release tab, then slide each disk drive assembly about 2 inches to the front of the system unit (Figure 2-35).

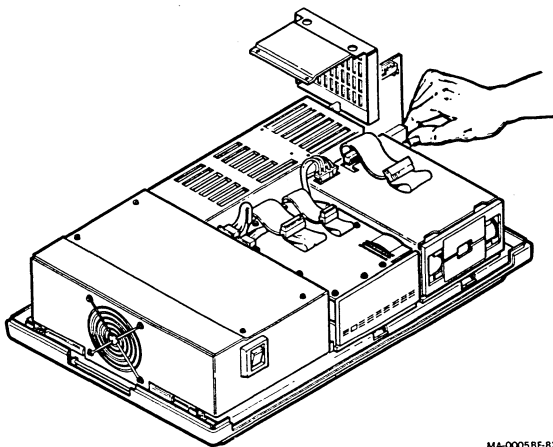

MA-0005BF-82

Figure 2-33 I/O Option Boards

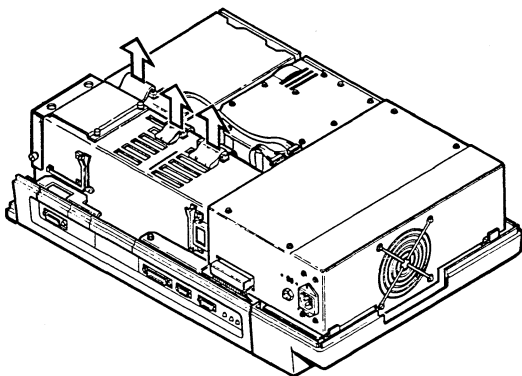

MA-0008R-B2

Figure 2-34 Diskette Drive I/O Cable and Hard Disk I/O Cables

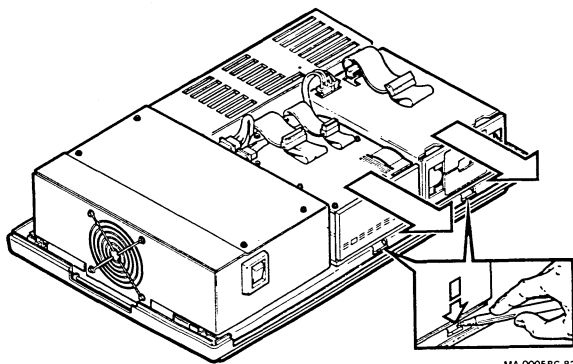

MA-0005BG-B2

Figure 2-35 Sliding Out Disk Drive Assemblies

6. Loosen the three captive screws that hold the system module to the chassis (Figure 2-36).
7. Slide the entire system module to the rear of the system cabinet about 2 inches (Figure 2-37). Disconnect the 16-pin power connector from the system module. You can disconnect the cable by pulling straight up on the white cable pull (Figure 2-37).
8. Remove the system module from the chassis (Figure 2-38).

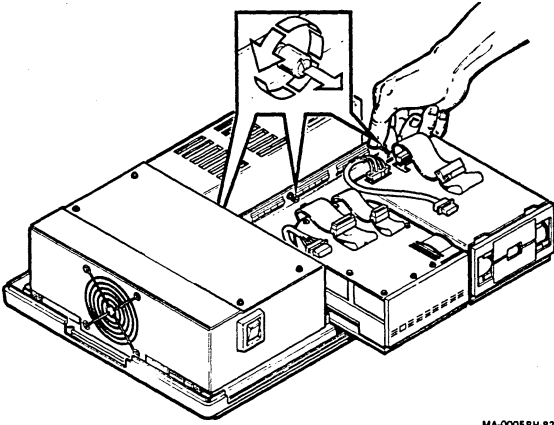

MA-00058H-82

Figure 2-36 Captive Screws on Chassis

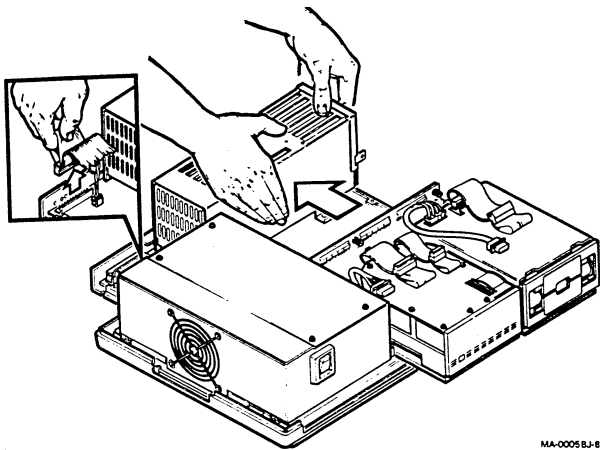

MA-0005 BJ-82

Figure 2-37 System Module and 16-Pin Power Connector

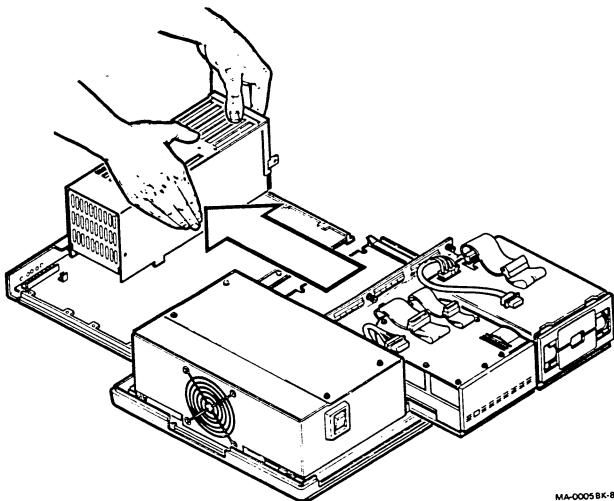

MA-0005 BK-82

Figure 2-38 Removing System Module

9. Using a Velostat kit and wrist strap, find the socketed identification PROM (E60) shown in Figure 2-39.
10. Use a flat-blade screwdriver to lift out the PROM at location E60 (Figure 2-40).
11. With the notch to the left, carefully press the PROM into the socket on the new board.

CAUTION

Press evenly. Do not bend the pins.

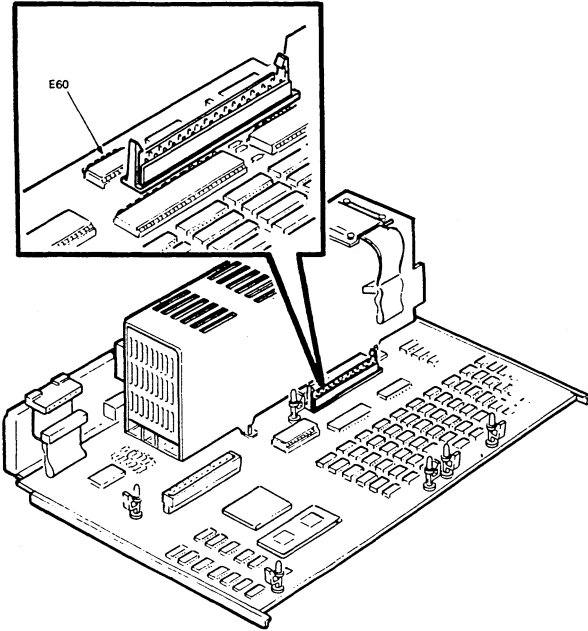

MA 1143-84A

Figure 2-39 System ID PROM

NOTES

The system module may contain up to two option daughter boards. You must remove them from the system module before returning the module for repair (Paragraph 2.10).

Tell the customer to leave the Professional computer turned on for at least 48 hours. This will fully charge the battery that powers the real-time clock and calendar on the system module.

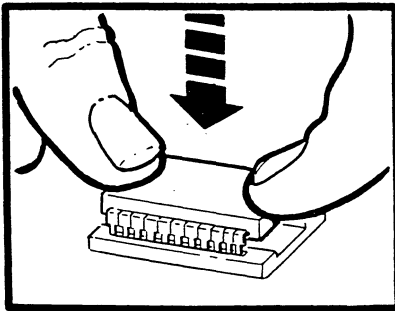
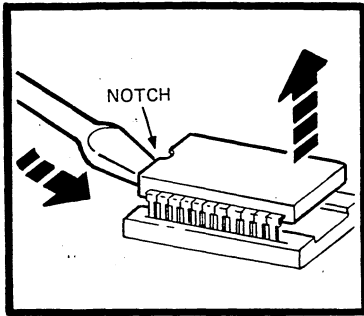

MA-0704-84A

Figure 2-40 Removing and Replacing ID PROM

2.10 EXTENDED BIT MAP AND MEMORY DAUGHTER BOARDS

Remove either the extended bit map (EBO) or memory daughter boards as follows.

1. Remove the top cover (Paragraph 2.3).
2. Remove the system module (Paragraph 2.9)
3. Release the option daughter boards from the four plastic standoffs (Figure 2-41). The left board is the extended bit option and the right board is the memory daughter module.
4. Pull each option daughter board up and off the system module (Figure 2-42).

2.11 BATTERY PACK

Remove the battery pack as follows.

1. Remove the top cover (Paragraph 2.3).
2. Slide the system module about 2 inches to the rear of the cabinet, then disconnect the 2-wire battery pack cable from the system module (Figure 2-43).

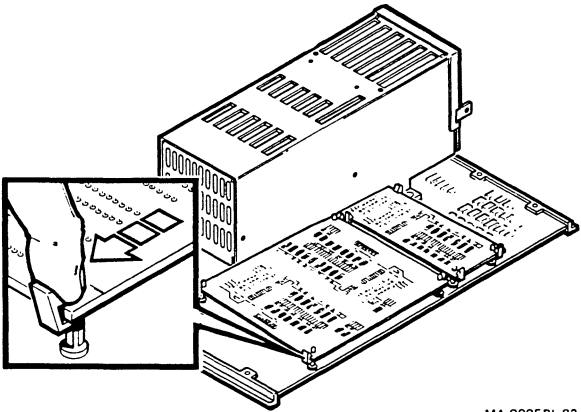

MA-0005BL-82

Figure 2-41 Releasing Option EBO Board

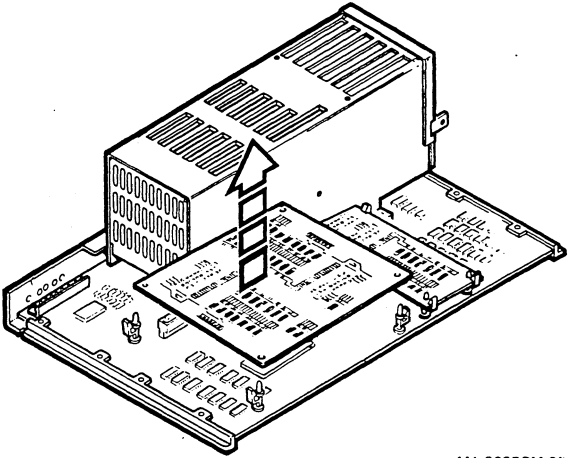

MA-0005BM-82

Figure 2-42 Removing Option EBO Board

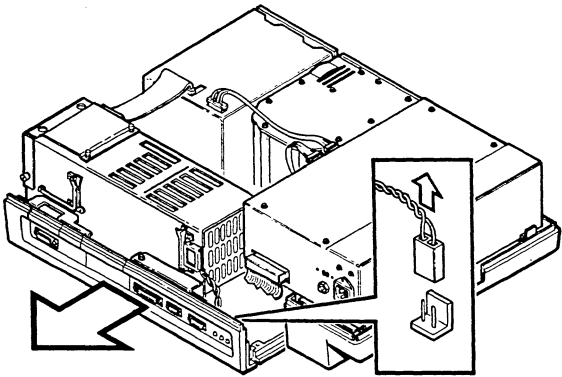

MA-0008T-82

Figure 2-43 System Module and 2-wire Battery Pack Cable

3. Open the battery pack holder and remove the battery pack. The battery pack is mounted on the rear of the card cage (Figure 2-44).

NOTE

After you replace the battery pack, tell the customer to leave the Professional computer turned on for at least 48 hours. This will fully charge the battery that powers the real-time clock and calendar on the system module.

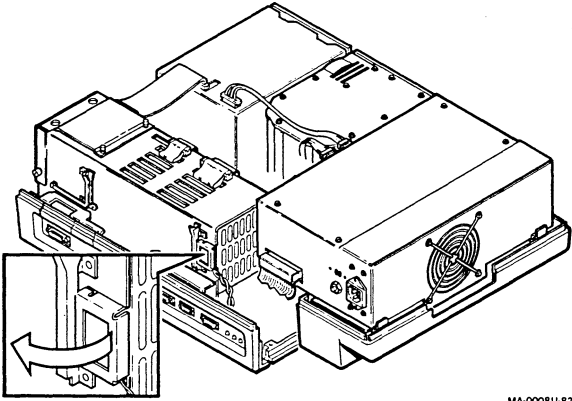

MA-0008U-82

Figure 2-44 Removing Battery Pack

2.12 I/O BOARDS

Remove any I/O board as follows.

CAUTION

Use a static protection kit (PN 29-11762-00) when handling any internal components.

1. Remove the top cover (Paragraph 2.3).

NOTE

If you are removing the real-time interface (handle ID number 000046), go to Paragraph 2.12.1.

If you are removing the telephone management system (handle ID number 000041), go to Paragraph 2.12.2.

2. Remove the three screws holding the cable cover/door to the card cage and remove the cable cover/door (Figure 2-45).

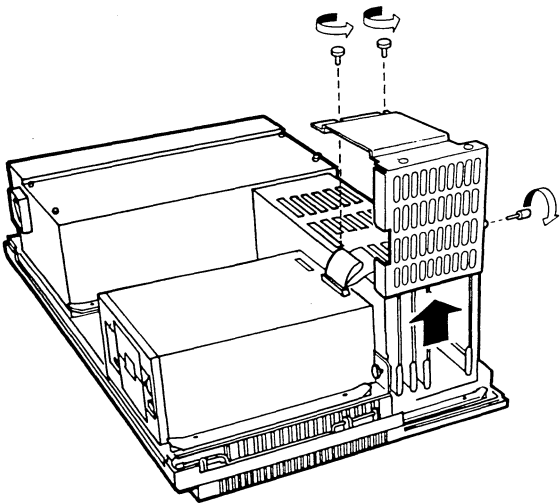

MA-0044-84A

Figure 2-45 Cable Cover/Door

3. Disconnect any cables connected to the I/O board through the card cage slots. You can disconnect each cable by pulling straight up on the white cable pull (Figure 2-46).

NOTE

The hard disk I/O board for an internally mounted hard disk drive must go in slot 1. The real-time interface must go in slot 6.

4. Pull the I/O board handle out. The handle slides out about 1 inch (Figure 2-47).
5. Turn the handle to the right 90 degrees, toward the rear of the chassis (Figure 2-48). The pin-spreading sound is normal for this type of connector.

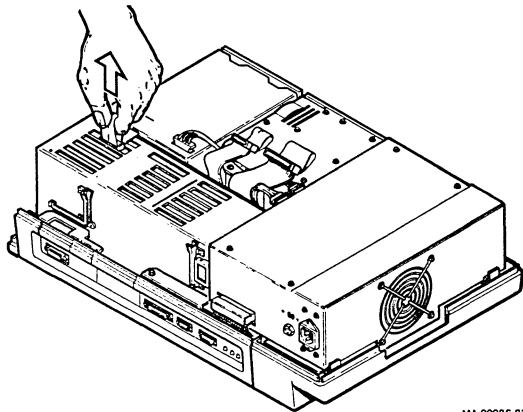

MA-0085-82

Figure 2-46 Cables Connected to I/O Board

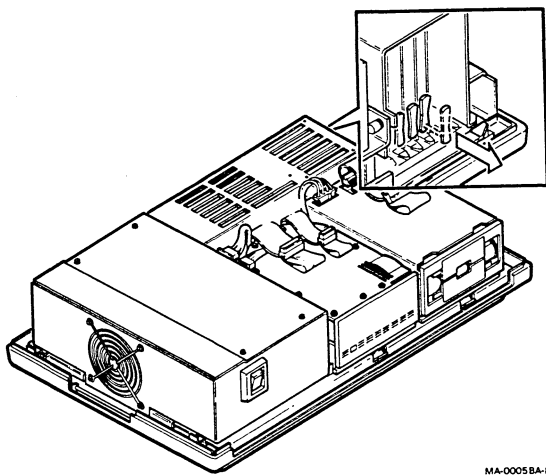

MA-0005BA-B2

Figure 2-47 I/O Board Handle

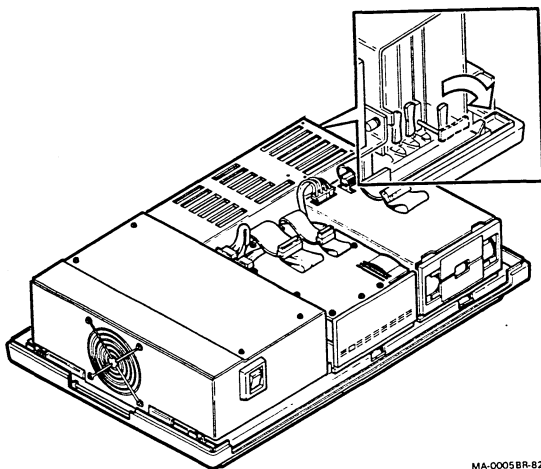

MA-0005BR-B2

Figure 2-48 Turning I/O Board Handle

6. Slide the I/O board straight out (Figure 2-49).

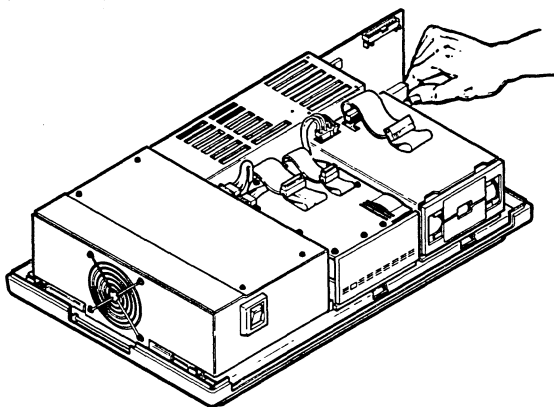

MA-000580-82

Figure 2-49 Sliding Out I/O Board

2.12.1 Real-Time Interface

Remove the real-time interface as follows.

1. Disconnect any device attached to the internal cable 62-pin connector. (This internal cable is only for the real-time interface.)
2. Remove the internal cable by unscrewing the two screws at the top of the cable and the two screws at the bottom connector (Figure 2-50).
3. Slide the internal cable up to disconnect it from the real-time interface.

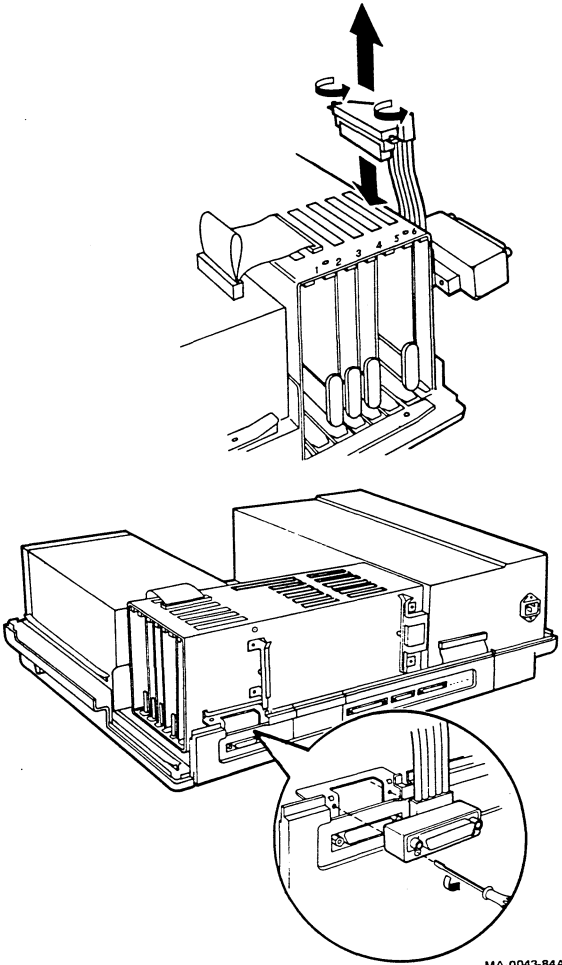

MA-0043-84A

Figure 2-50 Removing Internal Cable

4. Remove the three screws that hold the combined card cage shield-door to the card cage, then remove the entire shield-door assembly by lifting it straight up (Figure 2-51).
5. Pull the I/O board handle out. The handle slides out about 1 inch (Paragraph 2.12).
6. Turn the handle to the right 90 degrees. The pin-spreading sound is normal for this type of connector.
7. Slide the real-time interface straight out.

Replace the real-time interface by following these steps in reverse. The real-time interface must go in slot 6.

Let the power-up self-test run to completion before you connect any external devices to the real-time interface.

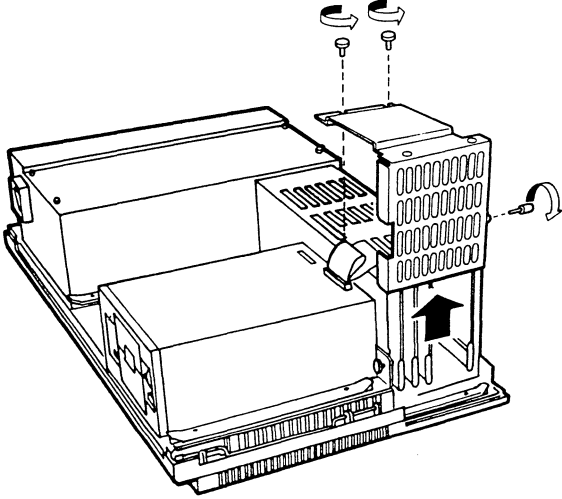

MA-0044-B4B

Figure 2-51 Shield Door Assembly

2.12.2 Telephone Management System (TMS)

TMS has two boards and may have accessories attached. The TMS controller is inside the card cage. The TMS telephone line interface (TLI) is mounted on back of the card cage; it lifts straight up. The optional voice unit connects to the TLI, and other accessories plug into the voice unit.

2.12.2.1 TMS Controller – Refer to Paragraph 2.12.

2.12.2.2 Telephone Line Interface – Remove the TLI as follows.

1. Disconnect any cables connected to the TLI.
2. Lift the TLI straight up (Figure 2-52).

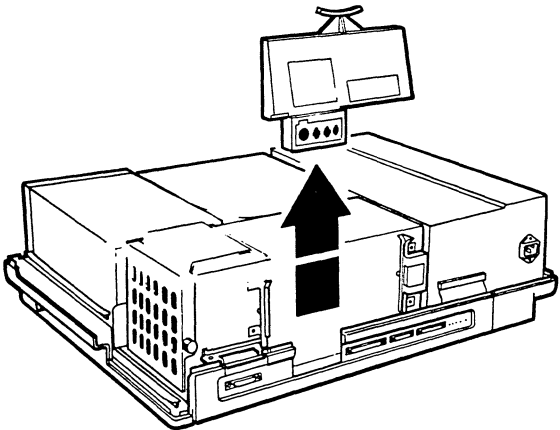

MA-0048B-84

Figure 2-52 Telephone Line Interface (TLI)

2.12.2.3 Voice Unit and Accessories – Remove the voice unit and accessories as follows.

1. Disconnect the voice unit from the TLI (Figure 2-53).
2. Unplug the accessories from the voice unit (Figure 2-53).

2.13 KEYBOARD

Remove the keyboard as follows.

1. Turn system power off.
2. Disconnect the keyboard cable from the rear of the monitor.

NOTE

The keyboard is a single FRU; replace the entire keyboard.

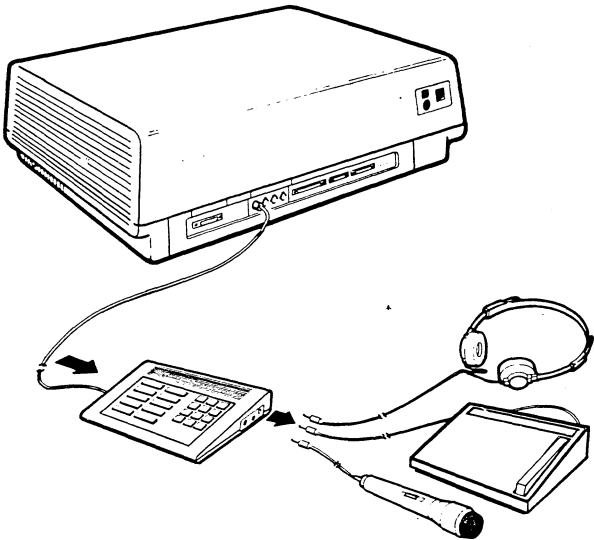

MA-0049-84

Figure 2-53 Voice Unit

2.14 REMOVING AND REPLACING THE ANALOG DATA MODULE (ADM)

When you have isolated the faulty ADM FRU, perform the following procedures to remove and replace it.

2.14.1 Opening the ADM Chassis

Open the ADM chassis as follows.

1. Turn off the on/off switch and remove the power cord from the ADM.
2. Turn the ADM upside down.
3. Remove the four screws on the bottom of the ADM (Figure 2-54).

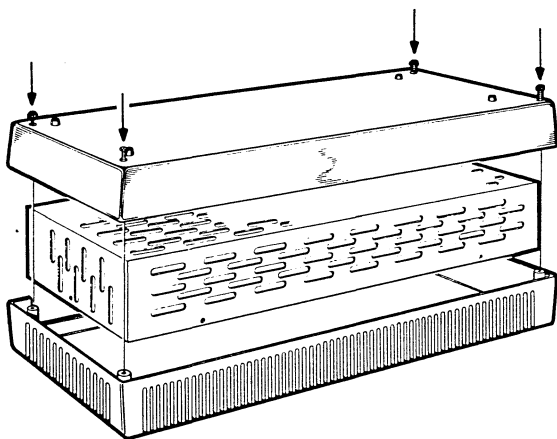

MR-13248
MA-1405-84

Figure 2-54 Removing Screws from Bottom of ADM

4. Turn the ADM right-side up again.
5. Remove the six phillips screws that hold the metal shield on (Figure 2-55). Remove the shield. The interior of the ADM is now exposed. Figure 2-56 shows the four FRUs.

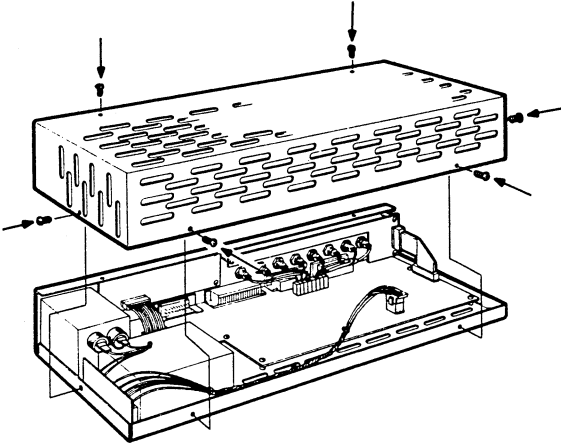

MR-13250
MA-1406-84

Figure 2-55 Removing Shield

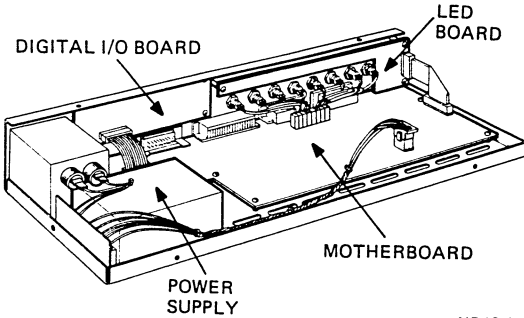

MR-13251
MA-1407-84

Figure 2-56 ADM FRUs

2.14.2 Removing and Replacing the Power Supply

Remove and replace the power supply as follows.

1. Remove the plastic shield that protects the connectors by removing the two screws that hold it on (Figure 2-57, step 1).
2. Disconnect the six cables from the cable connector strip (Figure 2-57, step 2). Note that the cables are color coded as shown in Table 2-1.

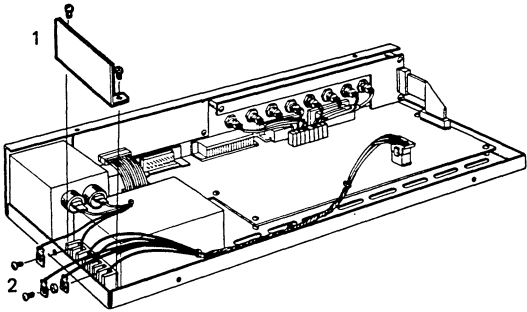

MR-13252
MA-1408-84

Figure 2-57 Disconnecting Cables and Connector Strip

Table 2-1 ADM Power Supply Cable Connections

Terminal	Color
AC*	Blue
AC*	Brown
RN	Black
+5	Red
-V	Blue
CM	White
+V	Orange

* The two ac connections come from the power cord input on the front panel. The other connections are bundled together and connect to the mother board.

3. Remove the four screws that hold the power supply from the bottom (Figure 2-58).
4. Replace the power supply by performing 1 through 3 in reverse.

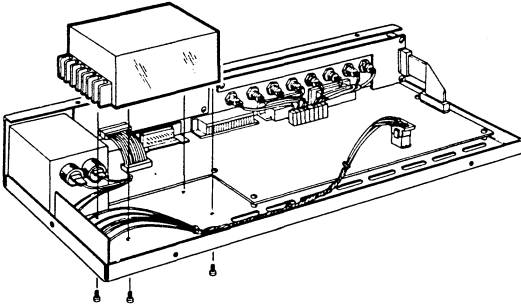

MR-13253
MA-1409-84

Figure 2-58 Replacing Power Supply

2.14.3 Removing and Replacing the LED Board

Remove and replace the LED board as follows.

1. Disconnect the cable from the LED board (Figure 2-59). Note the red edge.
2. The 5-volt jack is attached to the LED board. Unscrew the nut that holds the jack to the front panel, and remove the nut, metal washer, and fiber washer (Figure 2-60). Inside the ADM, a swedge washer seals the jack against the panel. Note the ridge on the rubber washer when you remove it so you can replace the washer correctly.

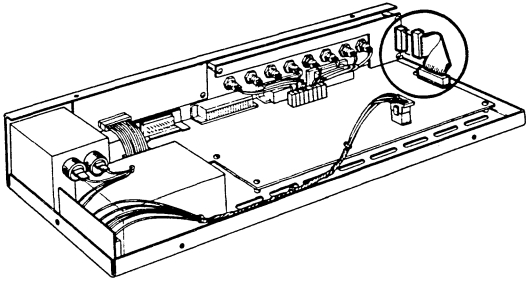

MR-13254
MA-1410-84

Figure 2-59 Disconnecting Cable from LED Board

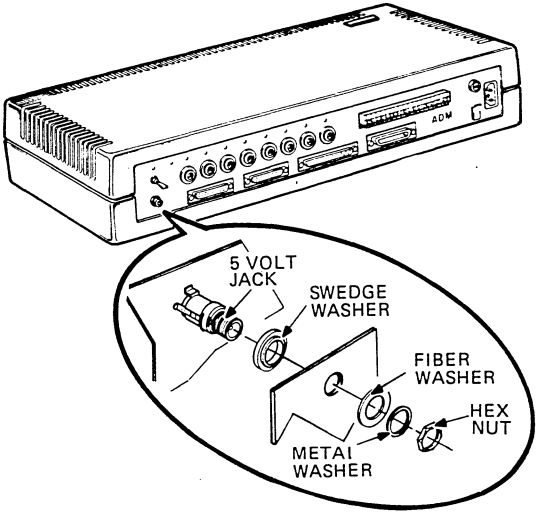

MR-12835
MA-1416-84

Figure 2-60 Removing 5-Volt Jack

3. Remove the three screws that hold the LED board in place (Figure 2-61).
4. Replace the LED by performing steps 1 through 3 in reverse. The red edge of the cable should be up.

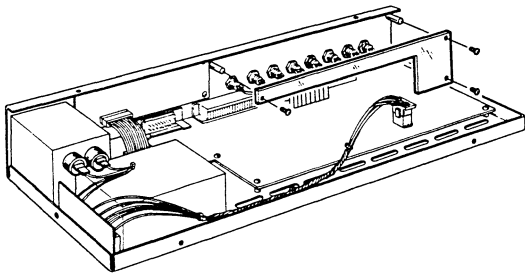

MR-13255
MA-1411-84

Figure 2-61 Removing LED Board

2.14.4 Removing and Replacing the Motherboard

Remove and replace the motherboard as follows.

1. Disconnect all cables from the motherboard (Figure 2-62). When you disconnect the connectors from the analog channel inputs, note that there are two empty sockets on the motherboard. These are the two left-most connectors (while you are facing the back of the ADM). When you reinsert the cables, start from the right side and connect the analog channels sequentially.
2. Remove the eight hex-nuts that hold the two serial line unit connectors, the IEEE connector, and the 62-pin connector (Figure 2-63). These hex-nuts are on the ADM's front panel.
3. Remove the seven screws that hold the motherboard in place (Figure 2-64).
4. Replace the motherboard by performing steps 1 through 3 in reverse.

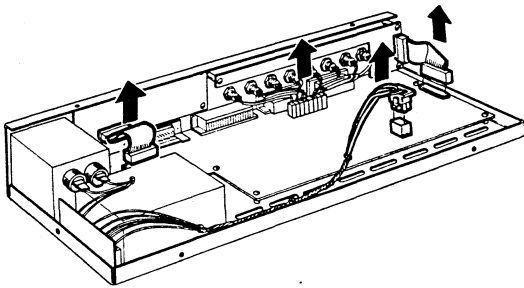

MR-13256
MA-1412-84

Figure 2-62 Disconnecting Cables from Motherboard

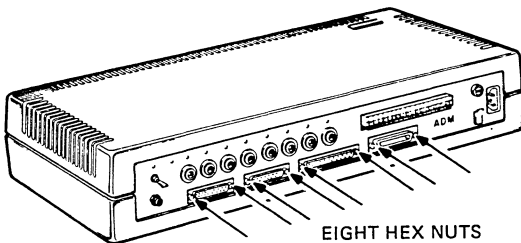

MR-12835
MA-1417-84

Figure 2-63 Removing Eight Hex-Nuts

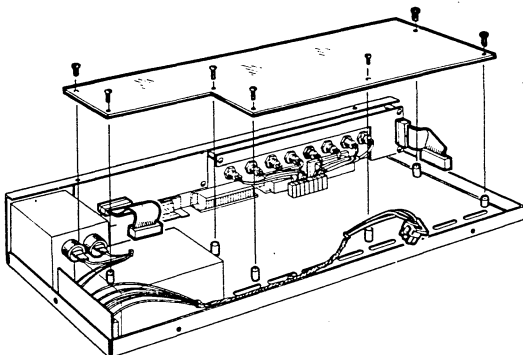

MR-13257
MA-1413-84

Figure 2-64 Removing Motherboard

2.14.5 Removing and Replacing the Digital I/O Board

Remove and replace the digital I/O board as follows.

1. Disconnect the cable to the digital I/O board (Figure 2-65). Note the red edge on the cable.
2. Remove the five screws that hold the digital I/O board (Figure 2-66). The screw in the middle top of the board has an insulating washer on it. Make sure you save this washer and replace it when you replace the board.
3. Replace the digital I/O board by performing steps 1 and 2 in reverse. The red edge of the cable should be on the right (while you are facing the back of the ADM).

2.15 HARD DISK EXPANDER BOX

The PC3XA expander box includes three major assemblies that you may need to replace: the RD5X hard disk drive, the power supply, and the load resistor assembly.

2.15.1 Hard Disk Drive

Replacing the optional disk drive requires disconnecting the system data cables (Part A) and opening the expander box (Part B).

NOTE

Turn off power to the system unit and expander box.

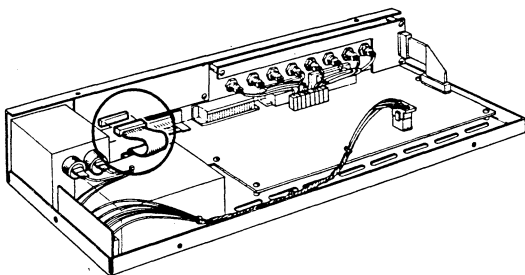

MR-13258
MA-1414-84

Figure 2-65 Disconnecting Cables from Digital I/O Board

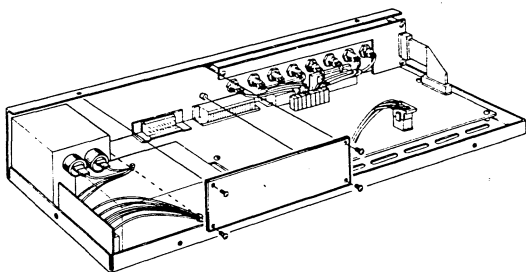

MR-13259
MA-1415-84

Figure 2-66 Removing Digital I/O Board

A. System Cables

On the system unit, disconnect the data cables as follows.

1. Loosen the retaining screws and detach the external data cable from the expander connector on the system unit (Figure 2-67).

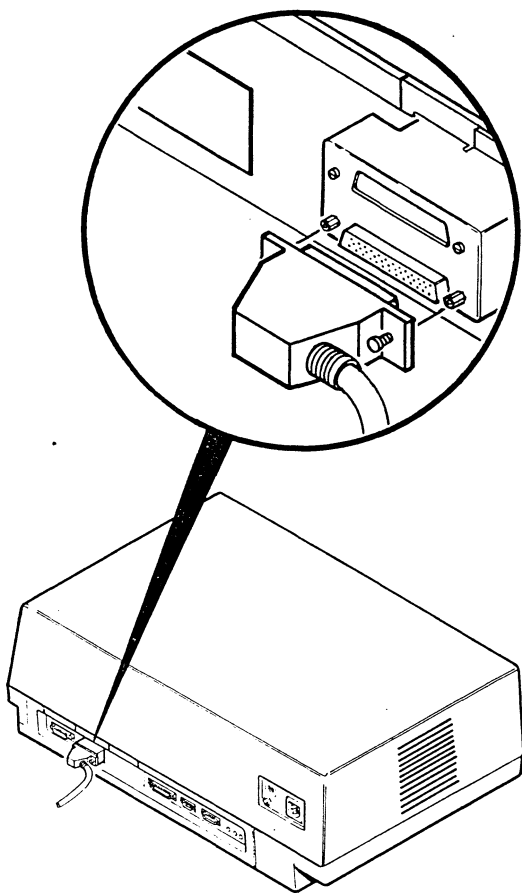

MA-0328-85

Figure 2-67 Disconnecting Data Cable (on System Unit)

- Gain access to the I/O card cage as described in Paragraph 2.12. Disconnect the two internal cable connectors from the hard disk option module (Figure 2-68).

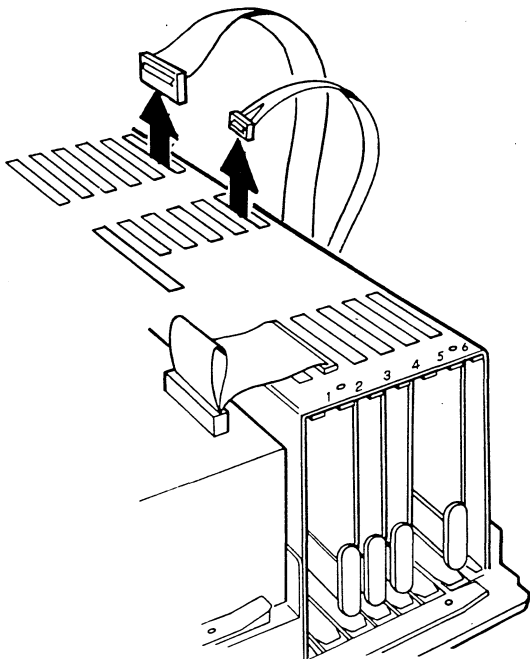

MA-0326-858

Figure 2-68 Removing Internal Data Cables

3. On the system unit backpanel, lift the retainer bar and gently rock the data cable connector assembly back and forth until you can lift it out of the expansion box slot (Figure 2-69).

NOTE

If you need to replace the internal data cable (PN 17-010089-01), detach it from the connector assembly. Use a nut driver or a small wrench to remove the two screws that attach the cable connector to the metal enclosure. Then, pull the cable connector out of the connector assembly box.

CAUTION

Do not overtighten these screws when installing. They may twist off and break. This can cause intermittent errors or failure.

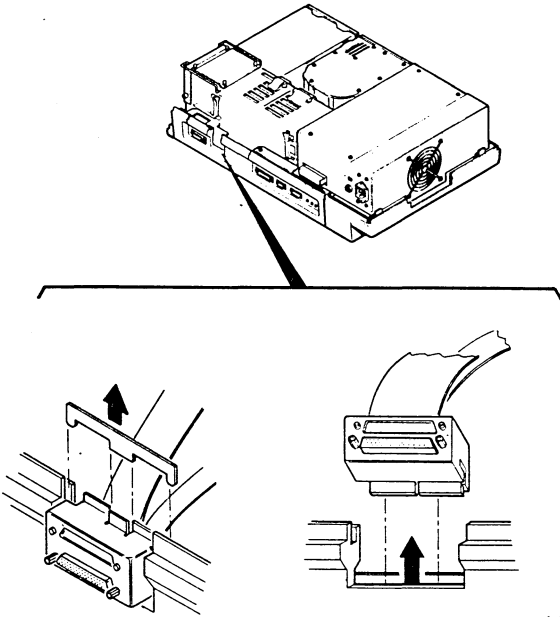

MA-1157-85

Figure 2-69 Removing Data Cable Connector Assembly

B. Expander Box

On the expander box, remove the hard disk drive as follows.

WARNING

Unplug the power cord from the expander box.

4. Lift the support bar. Remove the retaining screws and unplug the data cable from the box connector (Figure 2-70).

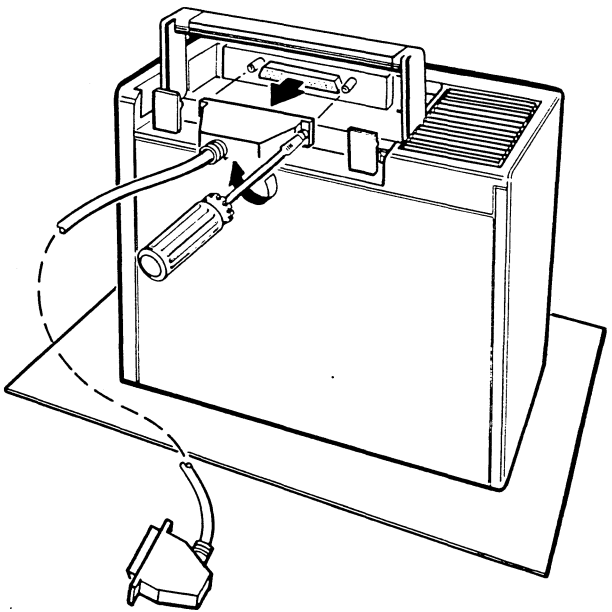

MA-0327-85C

Figure 2-70 Removing Data Cable on Expander Box

5. Place the expander box on its back. Remove the four cover screws (Figure 2-71).
6. Slide the cover up and off the expander box (Figure 2-72).
7. Return the expander box to its normal, horizontal position. Press down the front release and slide the drive halfway out of the expander box (Figure 2-73).

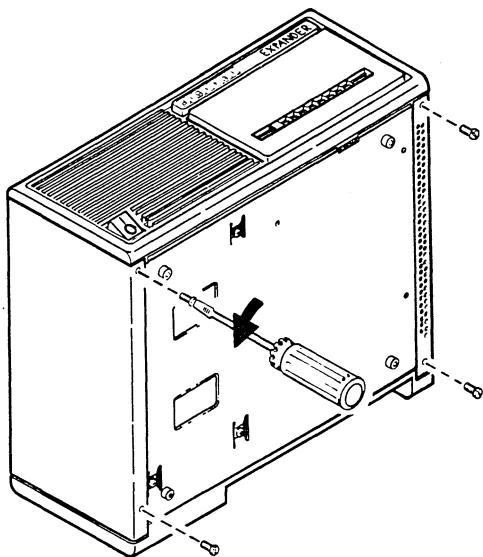

MA-0333-85B

Figure 2-71 Removing Cover Screws

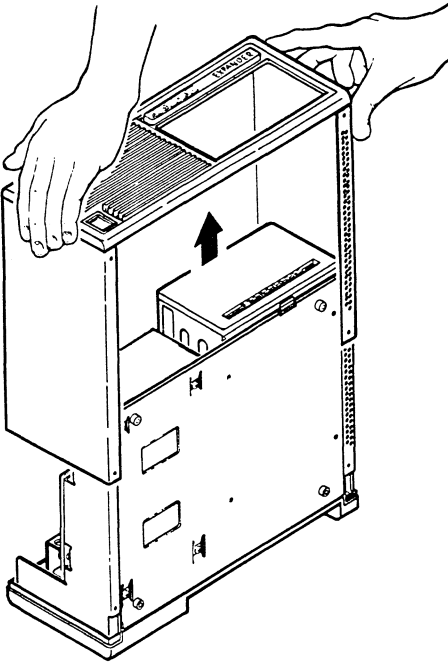

MA-0334-B5C

Figure 2-72 Removing Cover from Expander Box

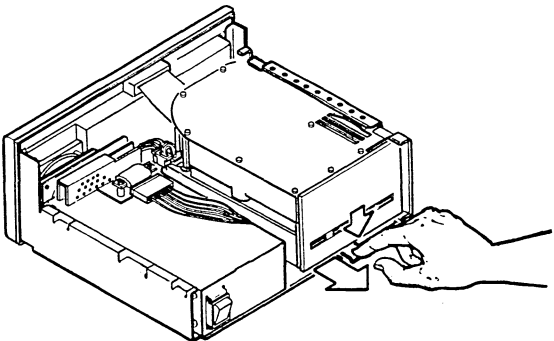

MA 0270-B5C

Figure 2-73 Releasing the Drive

8. Disconnect the power supply cable and the signal cables from the disk drive (Figure 2-74).

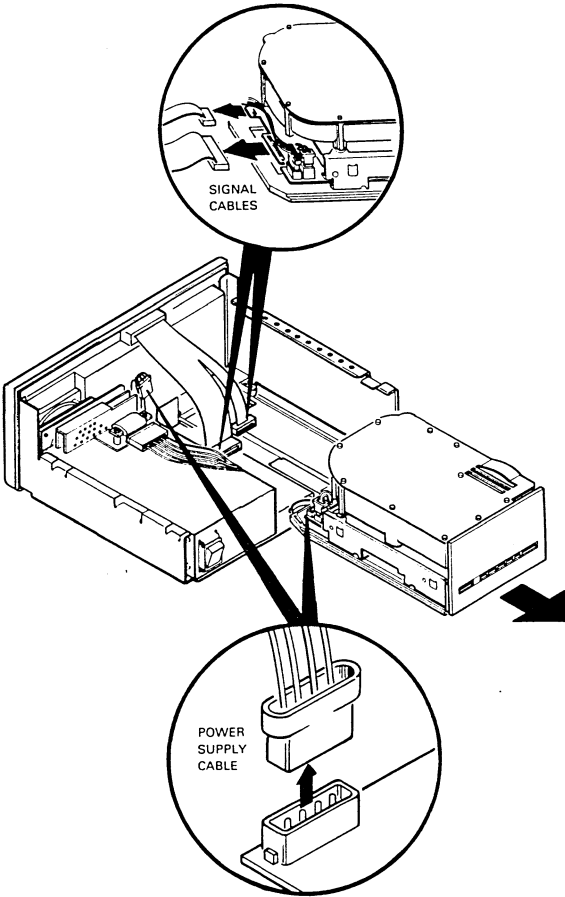

MA-0323-858

Figure 2-74 Removing Optional Hard Disk Drive

9. Remove the disk drive.

NOTE

If you have to replace the internal data cable, use a nut driver or a small wrench to remove the two screws that attach it to the expander box.

CAUTION

Do not overtighten these screws when installing. They may twist off and break. This can cause intermittent errors or failure.

2.15.2 Power Supply

Remove the power supply assembly (power supply and fan) as follows.

1. Remove the expander box cover (Paragraph 2.15.1, steps 4 through 7).
2. Disconnect the power supply and load resistor cables (Figure 2-75).

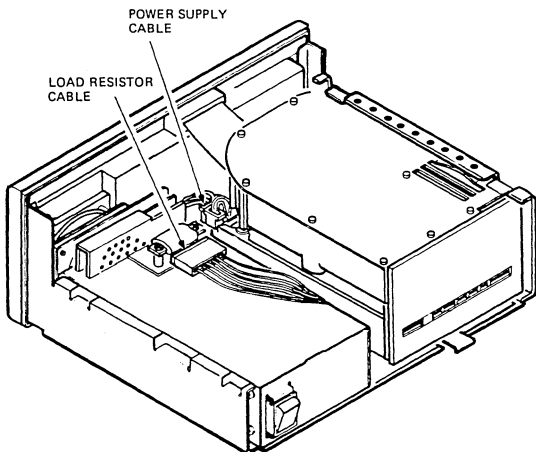

MA-0329-85A

Figure 2-75 Disconnecting Power Supply and Load Resistor Cables

3. Place the expander box assembly on its back and remove the four power supply mounting screws (Figure 2-76).
4. Put the expander box back into the horizontal position and remove the power supply by lifting it out.
5. On the power supply, remove the two top screws on the fan/load resistor bracket (Figure 2-77). Next slightly loosen the two bottom screws on the fan. Then pull the bracket up (with the load resistor assembly on it) and separate it from the power supply.
6. When installing a new power supply, replace the load resistor bracket on the power supply and connect the cables.
7. Secure the fan to the power supply with the four mounting screws.

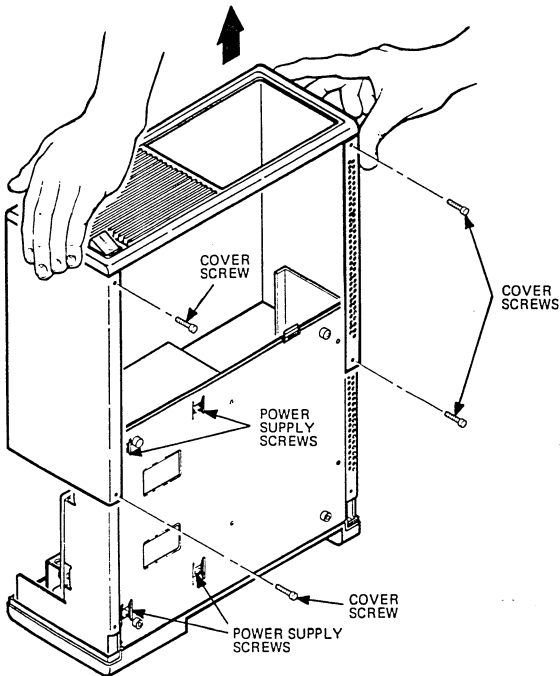

MA-0334-85A

Figure 2-76 Removing Mounting Screws

2.15.3 Load Resistor Assembly

Replace the +5 V load resistor assembly as follows.

1. Remove the expander box cover (Paragraph 2.15.1, steps 4 through 7).
2. On the power supply, detach the cable connector from the load resistor (Figure 2-75).
3. Release and remove the two nuts holding the load resistor to the bracket. Remove the load resistor (Figure 2-77).

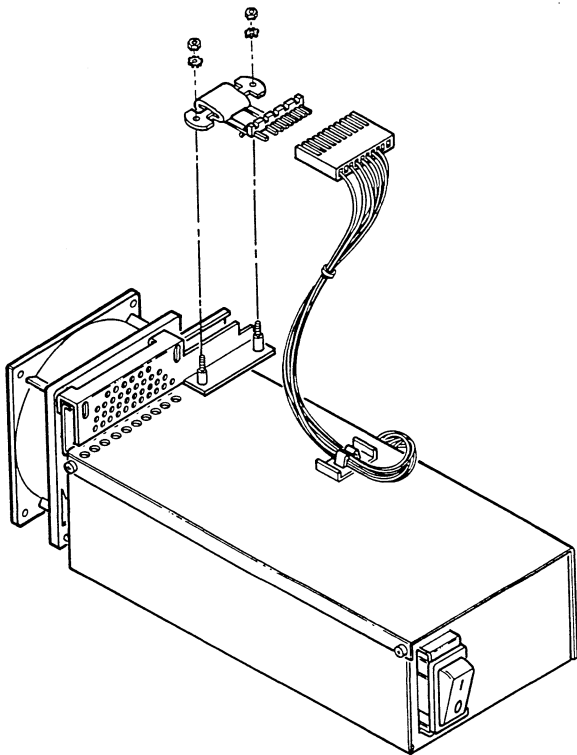

MA-1162-85

Figure 2-77 Power Supply/Load Resistor Assembly

2.16 SERIAL LINE UNIT OPTION

Remove the SLU option as follows.

Inside the system unit:

1. Gain access to the I/O card cage as described in Paragraph 2.12.
2. Remove the two thumbscrews from the cable hold-down bracket (Figure 2-78) above the SLU option module slot (slot 6).

NOTE

For a second SLU option module (slot 5), the second hold-down bracket is on top of the first bracket.

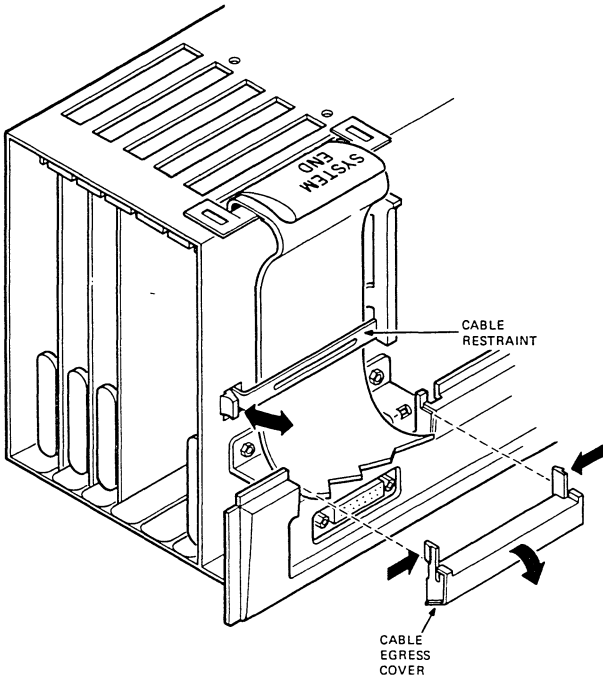

MA-D142A-85

Figure 2-78 Removing Internal SLU Option Cable

3. Remove and save the cable egress cover by pressing in on its tabs. Unclip the cable restraint and open it away from the card cage (Figure 2-78).
4. Unplug the SLU option cable from the SLU option module (Figure 2-79).

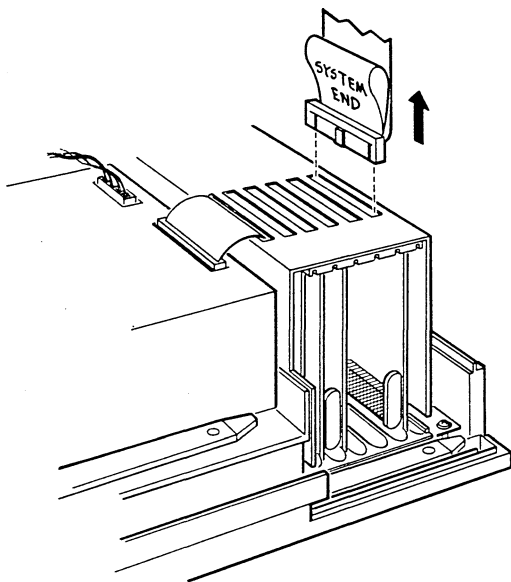

MA-0154-85A

Figure 2-79 Unplugging Internal SLU Option Cable

On back of the system unit:

5. Remove the communication cable(s) from the port connectors on the SLU interconnect box mounted on back of the system unit (Figure 2-80).
6. Pull the SLU interconnect box from the back of the system unit (Figure 2-80).

NOTE

The SLU box is attached to the system unit by two self-sticking pads. When installing a new box, first peel the paper off these pads.

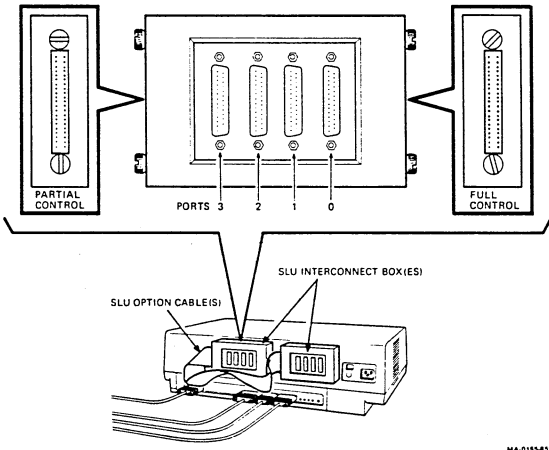
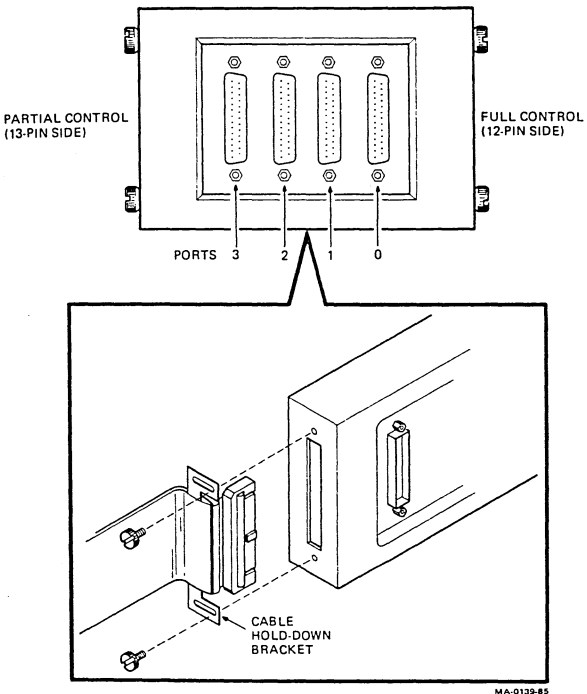

Figure 2-80 SLU Option Cabling and Interconnect Box

- On the SLU interconnect box, remove the two thumbscrews and the hold-down bracket that attach the option cable to the side connector (Figure 2-81). Unplug the SLU option cable from the side connector on the SLU box.

NOTE

When replacing the SLU option, make sure that you connect the SLU option cable to the correct side of the interconnect box as shown in Figure 2-81).



MA-0139-85

Figure 2-81 Removing SLU Option Cable

2.17 RECOMMENDED SPARES LIST

Table 2-2 is the recommended spares list (RSL) for the basic Professional system and the ADM.

Table 2-2 Recommended Spares List

Qty	Description	Part Number
PC380 Spares		
1	PC380 system module	KDJ11-CA
1	Power supply	H7862-C
1	RX50 diskette drive	RX50-AA
1	RX50 controller board	54-15058-00
1	RX50 diskette drive signal cable	17-00285-00
1	DC power cable (system board)	17-00280-00
1	DC power cable, RD drive (4 in)	17-00342-01
1	DC power cable, RX drive (6 in)	17-00342-02
1	Video cable (2-1/2 ft)	17-00283-01
1	Video cable (6 ft)	17-00283-00
1	Modem cable (10 ft)	17-00289-00
1	Modem cable (25 ft)	17-00289-01
1	Modem cable (50 ft)	17-00289-02
1	Printer cable (10 ft)	17-00300-00
1	Printer cable (25 ft)	17-00300-01
1	Printer cable (50 ft)	17-00300-02
1	Printer cable (100 ft)	17-00300-03
1	Console cable (10 ft)	17-00301-00
1	Console cable (25 ft)	17-00301-01
1	Console cable (50 ft)	17-00301-02
1	X.21 communications cable (10 ft)	17-00302-00
1	AC power cable (125 V)	17-00083-09
1	AC power cable (250 V)	17-00083-10
1	Professional 300 system unit enclosure	BA50-A
1	Floppy diskette kit	30-19448-02
1	Service kit suitcase	29-24198-00
1	Battery pack	12-19245-00
1	Communications port test connector	29-24795-00
1	Printer port test connector	29-24794-00
1	Fan	12-13185-03
1	Cable tie	90-07031-00
RCD50-A Spares		
1	RD50 disk drive	RD50-A
1	RD50 disk drive read/write board	29-24112
1	RD50 controller board	54-15134
1	RD50 disk drive cable (20 conductor)	17-00282
1	RD50 disk drive cable (34 conductor)	17-00286

Table 2-2 Recommended Spares List (Cont)

Qty	Description	Part Number
RD51-A Spares		
1	RD51 disk drive with slide plate	30-20004-02
1	RD51 disk drive read/write board	29-24665-00
1	DIP shunt (used on RD50 and RD51)	29-24115-00
1	Packaging container (used on RD50 and RD51)	99-90045-01
RCD52-A Spares		
1	28 megabyte 5-1/4 inch	RD52-A
1	Main PCB for RD52-A	29-24992-00
1	Address jumper	29-25007-00
1	RD52 hard disk controller module	54-15134-01
1	Data cable	17-00282-00
1	Control cable	17-00286-00
1	Motherboard	54-17659-01
1	LED board	54-17655-01
1	Digital I/O board	54-16368-01
1	120 V power supply	30-23564-01
1	Analog cable, 62 pin	17-00692-01
1	20-pin ribbon cable for LED board and Digital I/O board	17-00693-01
RD31 Spares		
1	Device electronics board	29-25527
1	20 Mb fixed disk	RD31-A
1	Jumper	12-14314-00
1	Standoff	90-00001-39
VC241-B Spares		
1	Extended bit map option (EBO) daughter board	54-16239-01
1	Color monitor cable (6 ft)	17-00284-00
VR201 Spares		
1	Video monitor (white phosphor)	VR201-A
1	Video monitor (green phosphor)	VR201-B
1	Video monitor (amber phosphor)	VR201-C

Table 2-2 Recommended Spares List (Cont)

Qty	Description	Part Number
LK201 Spares		
1	Keyboard (US)	LK201-AA
1	Keyboard (UK)	LK201-AE
1	Keyboard (Germany)	LK201-AG
1	Keyboard (Holland)	LK201-AH
1	Keyboard (France)	LK201-AP
1	Keyboard cable	17-00294-00
1	Keypad removal tool	74-27314-01
CP/M Option Spare		
1	CP/M softcard	54-15641-AA
Telephone Management System (TMS) Spares		
DTC11-A		
1	TMS controller board	54-15215-00
1	TMS TLI assembly	70-20405-00
1	Front plastic cover (for TLI)	74-28195-01
1	Rear plastic cover (for TLI)	74-28194-01
1	Telephone cable	17-00089-01
1	PRO/TMS communications test services diskette	ZBA-01-C3
DTC11-B		
1	Voice unit	DTC11-B
Real-Time Interface Spares		
1	Real-time interface module (PC3XX-AA)	54-15539-01
1	Internal cable	17-00404-01
1	Loopback connector	12-21246-01
1	Connector pod (for PC3XX-AB)	70-20631-01
1	Connector cable (for PC3XX-AB)	70-00386-01
1	Serial line unit cable	17-00370-01
1	IEEE cable	17-00371-01
1	Parallel cable	17-00379-01
1	Card cage door-shield	74-28266-02
1	PRO/real-time interface maintenance diskette	BL-X997B-BK

Table 2-2 Recommended Spares List (Cont)

Qty	Description	Part Number
DECNA		
1	DECNA module	54-15987-01
1	Transceiver cable (16-1/2 ft)	17-00321-00
1	Loopback connector	12-22196-01
1	PRO/DECNA maintenance diskette	ZBA03-C3
256-Kbyte Memory Option Spare		
1	MSC11-CK memory module	54-15488-KA
512-Kbyte Memory Option Spare		
1	MSC11-B memory daughter module	54-16234-LA
SLU Option Spares		
1	Option module	54-16622-01
1	Interconnect box	70-22026-01
1	Option cable	17-01042-01
1	PRO/Quad SLU	
1	Maintenance service diskette	ZBA06-C3
PC3XA Expander Box Spares		
1	Power supply (120 Vac)	H7845-BA
1	Power supply (220 Vac)	H7845-BB
1	Load resistor assembly	70-22594-01
1	External signal cable	17-00484-01
1	Internal (system unit) cable	17-01089-01
1	Internal (expander box) cable	17-01090-01

3 VIDEO MONITOR ALIGNMENT

3.1 GENERAL

This chapter describes the alignment of the VR201 video monitor. Always check each adjustment, because many adjustments affect each other. However, if a check shows the correct indication, skip that adjustment and go to the next procedure.

To perform the adjustments, you must use the video alignment pattern program on the maintenance application diskette. Make all adjustments under the following conditions.

- Normal video (white characters on dark background)
- 80 characters per line
- CRT alignment pattern on screen

NOTE

To adjust the VR241 color monitor, refer to the VR241-A Color Video Monitor Pocket Service Guide (EK-VR241-PS).

3.2 MONITOR ADJUSTMENTS

The following paragraphs list the alignment procedures for the VR201 video monitor. Figure 3-1 shows the location of all adjustments.

3.2.1 Removing the Monochrome Monitor

Remove the monochrome monitor as follows. (Refer to Paragraph 3.2.3 for the monochrome monitor alignment.)

1. Turn the system unit power switch off (Figure 3-2).

CAUTION

You must turn off the system unit power switch before disconnecting the video cable. The CRT anode will not discharge correctly if you do not follow this step.

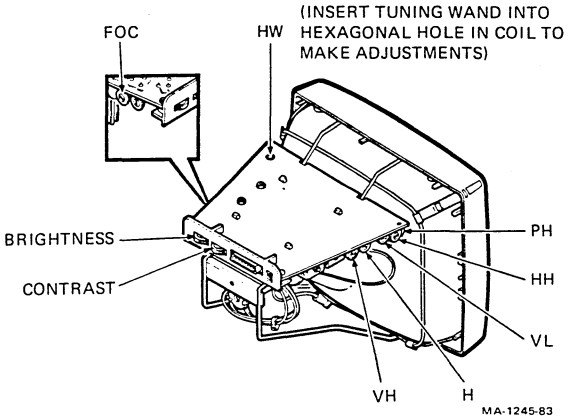

Figure 3-1 Video Adjustment Locations

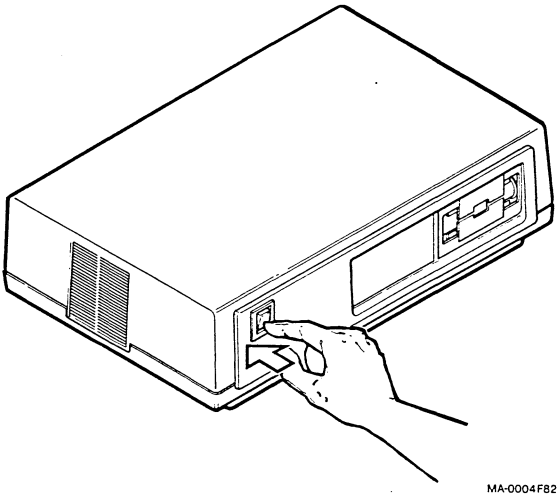
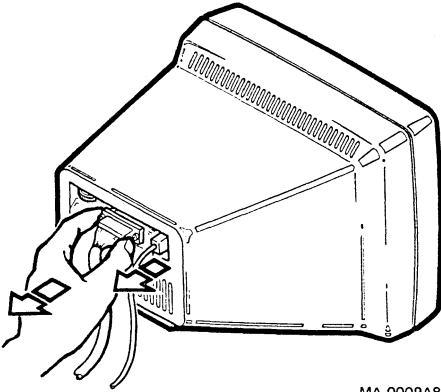

Figure 3-2 System Unit Power Switch

2. Disconnect the video and keyboard cables from the rear of the monitor (Figure 3-3).

NOTE

You must clean the face of the CRT after you finish with the monitor (cleaning fluid is PN 29-24791-00).



MA-0009A82

Figure 3-3 Monitor (Rear)

3.2.2 Monochrome Monitor Cover

Remove the monitor cover as follows. You need a small blade screwdriver and a small phillips screwdriver.

1. Monochrome monitor (Paragraph 3.2.1)

NOTE

In step 1, place a piece of paper under the monitor screen before turning it face down. This helps prevent scratches on the screen.

2. Extend the tilt mechanism foot completely. Then, carefully place the monitor face down on a flat surface. Use a small blade screwdriver to remove the plastic cap that covers the retaining screw (Figure 3-4).

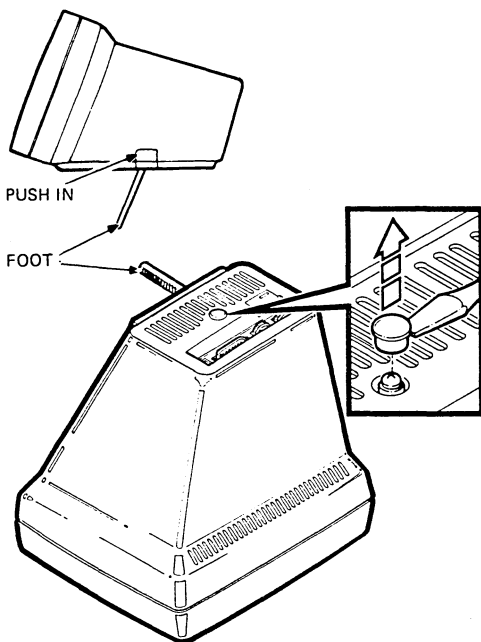

MA-0009G-82

Figure 3-4 Tilt Mechanism Foot and Retaining Screw Cap

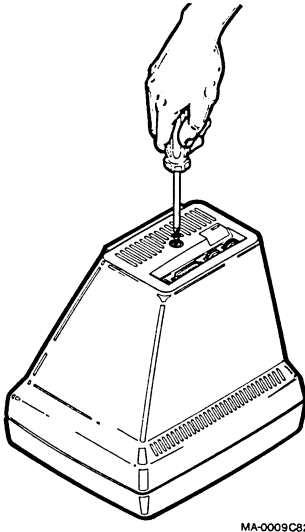

MA-0009C82

Figure 3-5 Retaining Screw

3. Use a phillips screwdriver to remove the screw that holds the cover to the monitor chassis (Figure 3-5).
4. Remove the cover by sliding it straight up (Figure 3-6).

CAUTION

When you replace the monitor cover, make sure the tilt mechanism foot is fully extended.

3.2.3 Preparations for Alignment

Prepare the monitor for adjustment as follows.

NOTE

In step 1, place a piece of paper under the monitor screen before turning it face down. This helps prevent scratches on the screen.

1. Place the monitor face down on a flat surface.

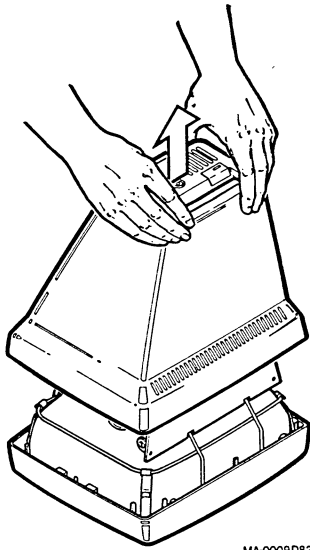

MA-0009D82

Figure 3-6 Removing Cover

2. Remove the monitor cover (Paragraph 3.2.2).

CAUTION

Do not touch any components. High voltage is present in the monitor.

3. Return the monitor to its normal operating position. Make sure the monitor is on a nonconductive surface to avoid any electrical shorts.
4. Reconnect the video and keyboard cables to the monitor.
5. Insert in drive 1 the P/OS diskette that came with the maintenance service package.
6. Turn the system power switch on.
7. Follow the instructions on the screen (Paragraph 1.4.7).
8. Turn the brightness and contrast controls to the minimum settings.

9. Increase the brightness control setting until the raster appears on the screen.
10. Decrease the brightness control setting until the raster just disappears from the screen.
11. Set the contrast control for the desired display intensity.
12. Remove the P/OS diskette and insert the maintenance application diskette into drive 1.
13. Enter service mode from the maintenance services menu and select the alignment pattern (Paragraph 1.4.8).

3.2.4 Vertical Hold

Adjust the vertical hold as follows.

1. Examine the monitor display for rolling or any other sign of vertical instability.
2. If necessary, adjust the vertical hold (VH) control to stabilize the display.

3.2.5 Horizontal Hold

Adjust the horizontal hold as follows.

1. Examine the monitor display for tearing or any other sign of horizontal instability.
2. If necessary, adjust the horizontal hold (HH) control to stabilize the display.

3.2.6 Focus

Adjust the focus as follows.

1. Examine the crosshatch pattern at the four corners and the center of the screen. Each line should be sharp and well defined.
2. If necessary, adjust the focus (FOC) control for the best overall display.

3.2.7 Vertical Centering and Rotation

Check the vertical centering and rotation as follows.

1. Measure the distance in two places between the alignment pattern and the monitor bezel (Figures 3-7 and 3-8). Use the scale on the template for the measurements. Make a note of each measurement and compare both measurements. The difference between the measurements should not be greater than ± 2 mm. If the difference is greater, go to step 4.

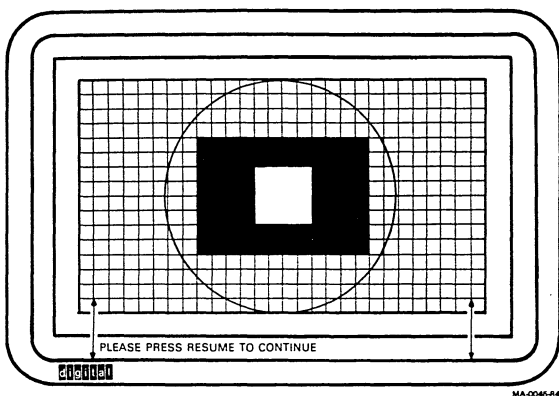

Figure 3-7 Universal Alignment Pattern
(Maintenance Services Version 2.0 and Lower)

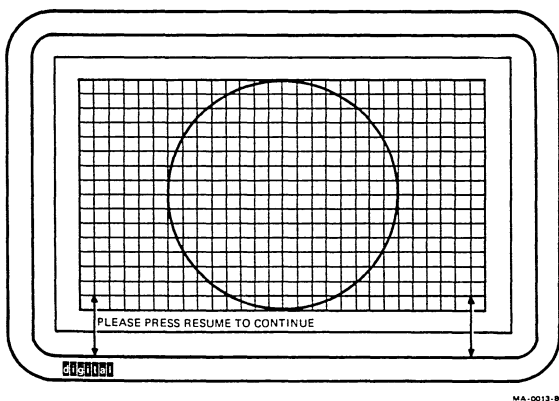

Figure 3-8 Universal Alignment Pattern
(Maintenance Services Version 3.0 and Higher)

2. Measure the distance between the top center edge of the alignment pattern and the monitor bezel. Also measure the distance between the bottom center edge of the alignment pattern and the monitor bezel. Use the scale on the template for the measurement.
3. Compare the measurements from step 2. The top measurement must be larger than the bottom. The difference between the two measurements must be from 2 mm to 14 mm. If either condition is not met, go to step 4.

NOTE

The electrical center of the screen is not the same as the apparent physical center of the screen. When the monitor is adjusted correctly, the screen display is offset toward the bottom of the monitor screen.

4. If any of the measurements are out of tolerance, replace the monitor assembly.

3.2.8 Horizontal Centering

Adjust the horizontal centering as follows.

1. Measure the distance between the center left edge of the alignment pattern and the monitor bezel. Use the scale on the template for the measurement. Make a note of the measurement.
2. Measure the distance between the center right edge of the alignment pattern and the monitor bezel. Use the scale on the template for the measurement. Make a note of the measurement.
3. Compare the measurements from steps 1 and 2. If the difference between the two measurements is greater than 6 mm, adjust the horizontal phase (PH) control.
4. Perform steps 1 and 2 again to verify the adjustment.
5. If necessary, check and adjust the aspect ratio (Paragraph 3.2.9).

3.2.9 Aspect Ratio (Horizontal Width and Height)

Adjust the aspect ratio as follows.

1. Select "White screen" in the alignment pattern menu.

NOTE

In the following steps, use a metric measuring tape (PN 29-25342) to measure the dimensions of the screen display. To avoid scratching the monitor screen with the metal clip of the tape, start the measurement at 10 cm (100 mm) as shown in Figure 3-9.

2. Check the screen display for measurements of about 203 mm wide and 127 mm high. Proceed to step 3 if adjustments are needed, otherwise go to step 5.
3. Adjust the horizontal width coil (HW) for a width of 203 mm by using a tuning wand (PN 29-23190-00). Refer to Figure 3-1.
4. Adjust the height (H) control for a height of 127 mm.
5. Return to the alignment pattern menu and select "Universal alignment pattern."
6. Check that the circle on the universal alignment pattern appears to be round.
7. If necessary, readjust the horizontal width coil (HW) or height (H) control to obtain the correct aspect ratio (round circle).
8. If necessary, check and adjust the horizontal centering (Paragraph 3.2.8) and vertical linearity (Paragraph 3.2.10).

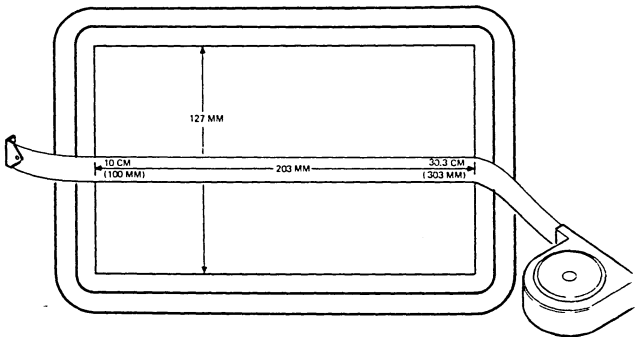

Figure 3-9 Measuring the Screen Display

3.2.10 Vertical Linearity

Adjust the vertical linearity as follows.

1. Check the height of the crosshatch pattern near the four corners of the display. The pattern should have the same height in all four corners.
2. If necessary, adjust the vertical linearity (VL) control until the pattern is the same height in all four corners.
3. If necessary, check and adjust the aspect ratio (Paragraph 3.2.9).

4 TESTING AND TROUBLESHOOTING THE DELNI UNIT

4.1 GENERAL

This chapter tells you how to test a DELNI unit with the PRO/DECNA maintenance services and the loopback connector that comes with the DECNA controller. With this test, you can also test the Professional computer, the DECNA controller, a DELNI unit, and the transceiver cable if the DELNI unit is attached to another DELNI unit or transceiver. Use the test if, on power-up, the error code shown on the monitor screen is 0111 or greater.

Refer to Paragraphs 1.4.1 and 1.15.4 for instructions on how to run the PRO/DECNA maintenance services. Before you test, make sure the green power-on indicator on the DELNI panel is on.

CAUTION

Tell everyone using the network that you are testing the DELNI unit and that they will be disconnected from the network until you are finished. The network users will not be able to transfer messages.

4.2 TESTING THE DELNI UNIT

Use the following procedure to test the DELNI unit.

1. Disconnect all cables from the DELNI unit, including the one attached to the Professional computer. Keep aside the cable that goes to the Professional computer.

NOTE

If the DELNI unit uses the ninth connector, disconnect the ninth connector also.

2. Attach the DECNA loopback connector to connector 9 on the DELNI unit. Set the Standalone/Connected switch in the connected position (up).

3. Using only the 5 meter (16.4 feet) cable attached to the Professional computer, connect the cable to each DELNI connector, in turn, and run the DECNA test.

CAUTION

Make sure the test is not running whenever you connect or disconnect the transceiver cable to or from the DELNI unit.

If any DELNI connector indicates an error on the test summary, the connector is defective and should not be used. You can still use the DELNI unit, except for the defective connector, until you get a replacement.

NOTE

If the DELNI unit connects to a H4000 transceiver, make sure the green indicator on the end of the loopback connector lights. If it does not light, power is not reaching the transceiver, and the transceiver cannot operate.

4.3 TESTING THE TRANSCEIVER CABLE

Use the following procedure if the DELNI unit is connected to another DELNI unit, or a transceiver, in a two-tier or connected DELNI local area network (LAN).

If you get an error indication on the DECNA and DELNI tests, use the following procedure. It tests the transceiver cable that connects the first DELNI unit to another DELNI unit or transceiver.

Use only one Professional computer connected to the first DELNI unit.

1. Set the Standalone/Connected switch in the connected position (up).
2. Remove the end of the transceiver cable from the second DELNI unit or transceiver.
3. Attach the loopback connector to this end of the cable and run the DECNA test.

NOTE

If the DELNI unit connects to a H4000 transceiver, make sure the green indicator on the end of the loopback connector lights. If it does not light, power is not reaching the transceiver, and the transceiver cannot operate.

If the test runs successfully, the transceiver cable is good and the second DELNI unit or transceiver is faulty.

You can test the second DELNI unit with the same procedure for a single DELNI unit. *Do not use the loop-back connector.* The second DELNI unit acts as a loop-back connector. Move the cable from one connector to the next. You can still use this DELNI unit with a defective connector until you get a replacement. If this test runs successfully, then the transceiver is faulty.

4.4 SOFTWARE PROBLEMS

In some situations, your network software may not be operating correctly. This can cause problems in transferring data and files. Make sure the latest version of your network software is installed. Contact your network manager or Digital for assistance.

A RELATED DOCUMENTATION

The following is a list of related hardware documentation for the Professional 300 series.

Professional 300 Series Technical Manual

Kernel System (Volume I)	EK-PC300-V1
Options (Volume II)	EK-PC300-V2

Real-Time Interface Module/Analog Data Module Technical Manual	EK-PCRTI-TM
--	-------------

These manuals describe the Professional 325, 350, and 380 computer systems and options to a detailed block diagram level. These manuals do not contain detailed schematic drawings. The *Professional 380 Field Maintenance Print Set* has detailed schematic drawings and is ordered separately.

Professional 350 Illustrated Parts Breakdown (IPB)	EK-SB350-IP
Professional 380 Illustrated Parts Breakdown (IPB)	EK-SB380-IP

These documents provide a detailed parts breakdown of the Professional's field replaceable units (FRUs). The following documents do not contain part numbers for components on the printed circuit boards. However, components are listed in the *Professional 380 Field Maintenance Print Set*, which is ordered separately.

DECNA Field Maintenance Print Set	MP-01895-01
LK201 Keyboard Field Maintenance Print Set	MP-01395-00
KDJ11-C Field Maintenance Print Set	MP-01957-01
VC241-B Field Maintenance Print Set	MP-01970-01
MSC11-B Field Maintenance Print Set	MP-02003-01
PC3XS CP/M Softcard Field Maintenance Print Set	MP-01730

PC3XX Real-Time Interface Module Field Maintenance Print Set	MP-01713
Professional 380 Field Maintenance Print Set	MP-01922-01
Telephone Management System Field Maintenance Print Set	MP-01654-01
VR201 Monochrome Monitor Field Maintenance Print Set	MP-01410-00

Each print set provides a complete set of electrical and mechanical schematic drawings.

B FRU EXPLODED VIEW DRAWINGS

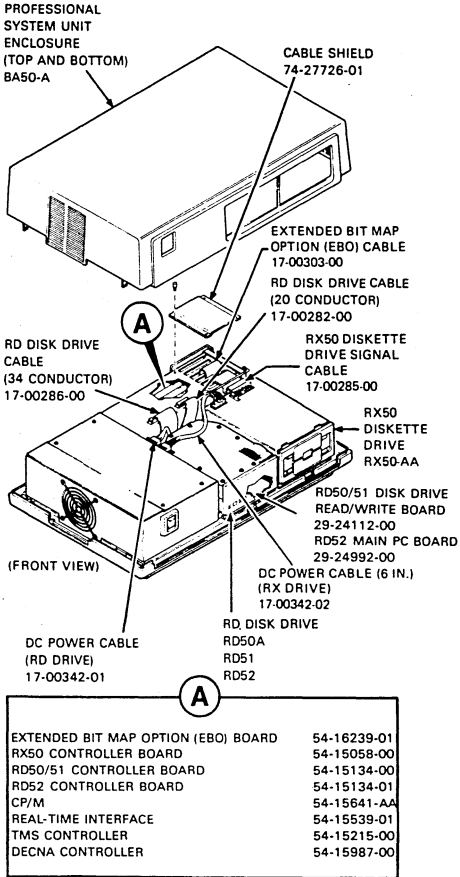

MA-0706-84A

Figure B-1 Professional 380 FRUs (Exploded View)
(Sheet 1 of 3)

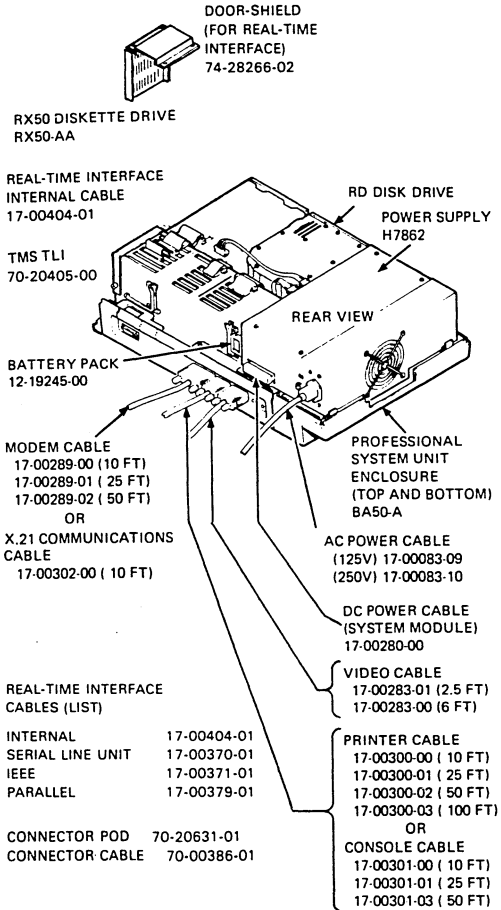

MA-1142-84A

Figure B-1 Professional 380 FRUs (Exploded View)
(Sheet 2 of 3)

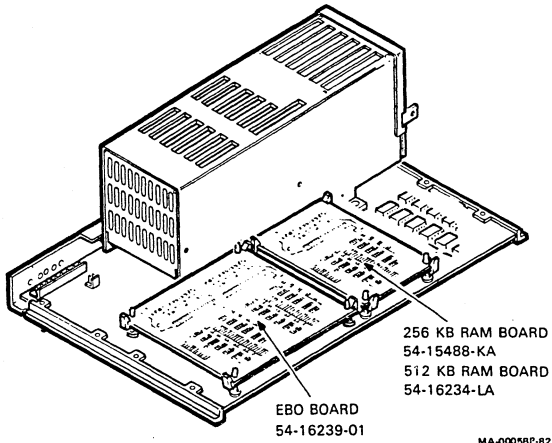

MA-00058P-82

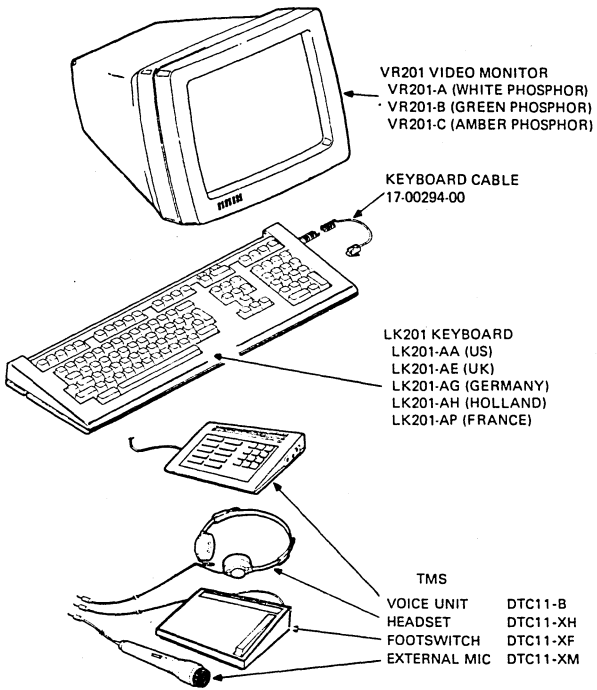

MA-0045-84

Figure B-1 Professional 380 FRUs (Exploded View)
(Sheet 3 of 3)

C FUNCTIONAL DIAGRAM

SYSTEM MODULE CONNECTOR PINS AND SIGNALS

Battery Connector - J3

Pin	1	+3.6 V
	2	Ground

DC Power Connector - J4

Pin	1	BDCOK
	2	KEY
	3	BPOK
	4	-12 Vdc
	5	+12 Vdc
	6	+5 Vdc
	7	+5 Vdc
	8	+5 Vdc
	9	+5 Vdc
	10	Ground
	11	Ground
	12	Ground
	13	Ground
	14	Ground
	15	Ground
	16	Ground

VIDEO1 Video/Keyboard Interface - J5

Pin	1	Blue return
	2	Green return
	3	Red return
	4	Mono return
	5	Ground
	6	Ground
	7	+12 Vdc
	8	+12 Vdc
	9	Blue video signal

- 10 Green video signal
- 11 Red video signal
- 12 Mono video signal
- 13 Mon Present
- 14 KBD RDATA
- 15 KBD TDATA

PRT1 Serial Printer Interface Connector - J6

- | | | |
|-----|---|---------------------|
| Pin | 1 | Protective ground |
| | 2 | Transmit data |
| | 3 | Receive data |
| | 4 | Not used |
| | 5 | Data terminal ready |
| | 6 | Data set ready |
| | 7 | Signal ground |
| | 8 | Ground |
| | 9 | Terminal (L) |

COMM1 Communications Interface - J7

- | | | |
|-----|----|--------------------------------|
| Pin | 1 | Protective ground |
| | 2 | Transmit data |
| | 3 | Receive data |
| | 4 | Request to send (RTS) |
| | 5 | Clear to send (CTS) |
| | 6 | Data set ready (DSR) |
| | 7 | Signal ground |
| | 8 | Carrier detected (CD) |
| | 9 | Not used |
| | 10 | Not used |
| | 11 | Not used |
| | 12 | Speed mode indicator (SPDMI) |
| | 13 | Not used |
| | 14 | Not used |
| | 15 | Transmit clock (STC) |
| | 16 | Not used |
| | 17 | Receive clock (RXC) |
| | 18 | Local loopback (LL) |
| | 19 | Not used |
| | 20 | Data terminal ready (DTR) |
| | 21 | Remote loopback (RL) |
| | 22 | Ring indicator (RI) |
| | 23 | Data signal rate select (DSRS) |
| | 24 | Transmit clock (TXC) |
| | 25 | Test indicator (TI) |

NET1 Network Interface - J9

Pin	1	Shield
	2	Collision presence +
	3	Transmit +
	4	Not used
	5	Receive +
	6	Power return
	7	Not used
	8	Not used
	9	Collision presence -
	10	Transmit -
	11	Not used
	12	Receive -
	13	+12 Vdc
	14	Not used
	15	Not used

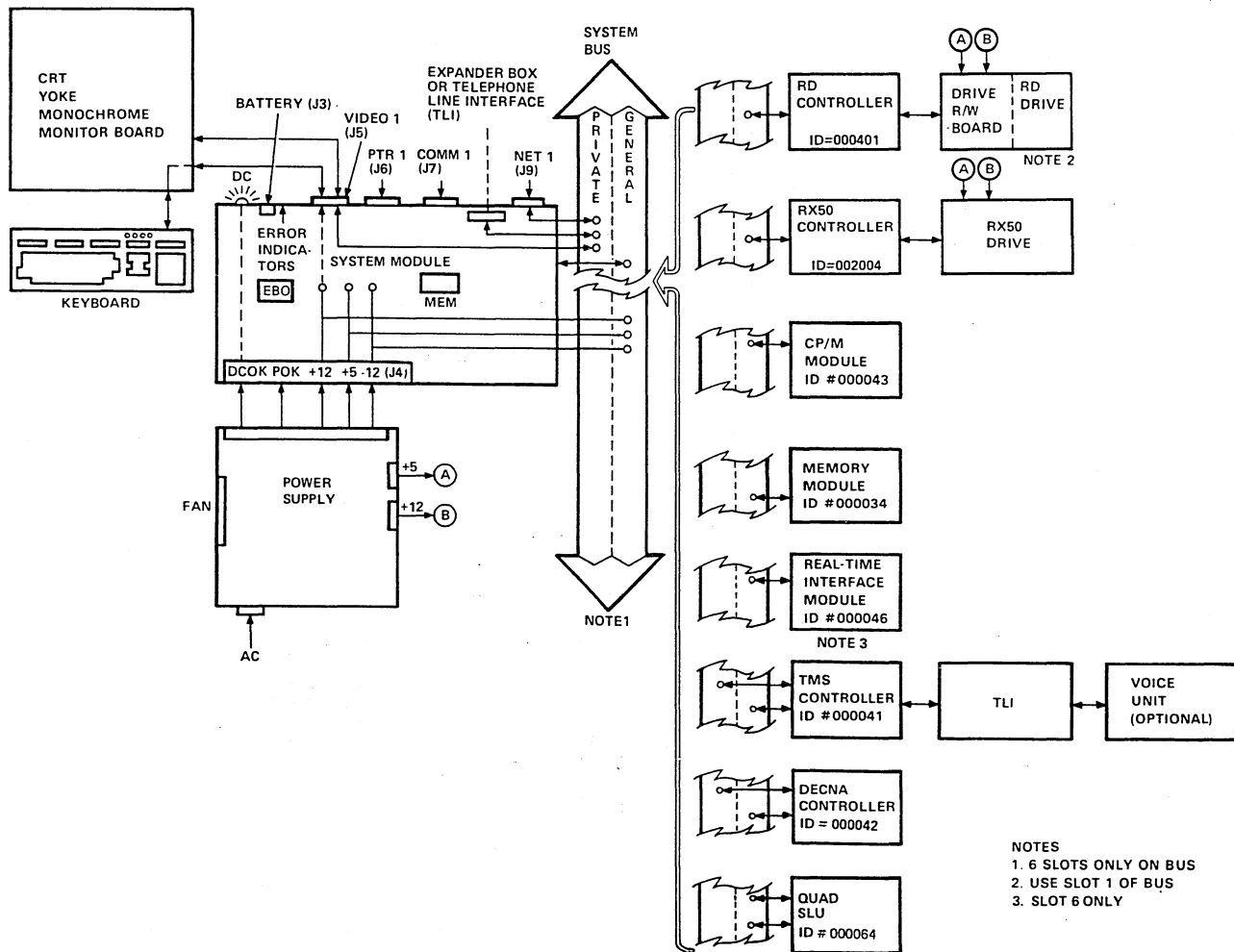

- NOTES
1. 6 SLOTS ONLY ON BUS
 2. USE SLOT 1 OF BUS
 3. SLOT 6 ONLY

Figure C-1 Functional Block Diagram